

JERNVED

3620908

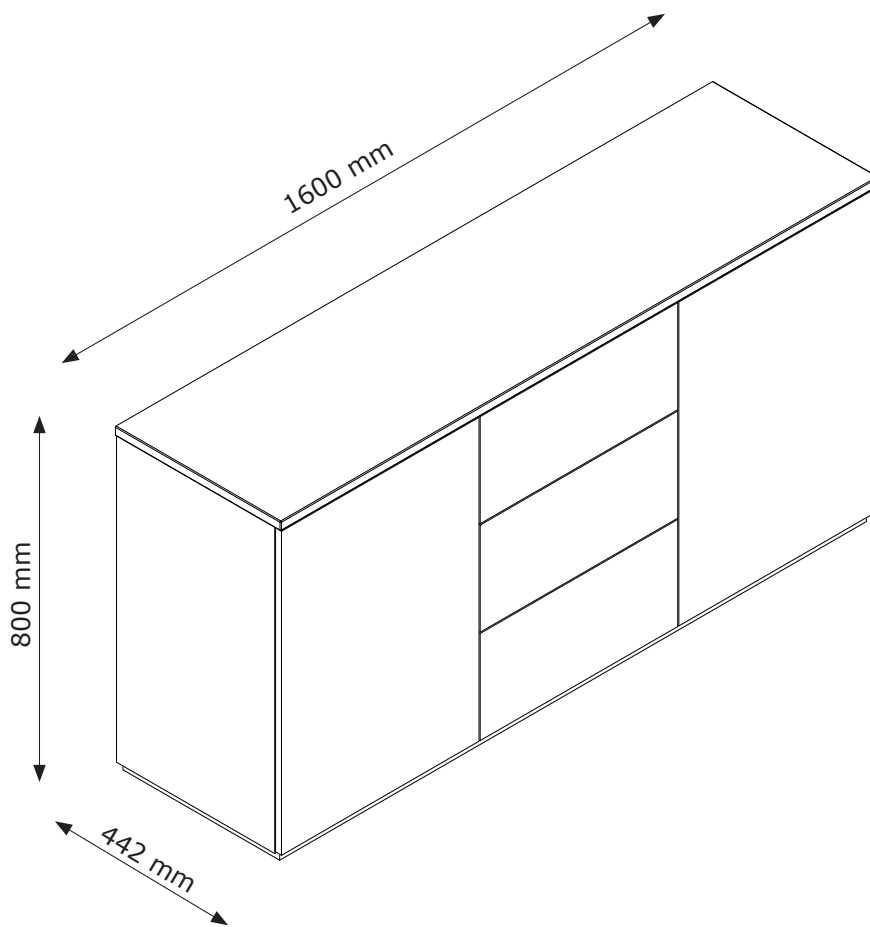



- GB: IMPORTANT INFORMATION!**
Please read the entire manual carefully before starting to assemble and/or using this product. Follow the manual thoroughly and keep it for further reference.
- DK: VIGTIG INFORMATION!**
Læs hele manualen grundigt igennem før samling og/eller brug af dette produkt. Følg manualen nøje, og opbevar den til senere brug.
- SE: VIKTIG INFORMATION!**
Läs bruksanvisningen i sin helhet innan du börjar att montera och/eller använda produkten. Följ bruksanvisningen noggrant och spara den för framtida referens.
- NO: VIKTIG INFORMASJON!**
Les hele bruksanvisningen nøye før du begynner å montere og/eller bruke dette produktet. Følg bruksanvisningen nøye, og ta vare på den for fremtidig bruk.
- FI: TÄRKEITÄ TIETOJA**
Lue käyttöohjeet kokonaan ennen tämän tuotteen kokoamista ja/tai käyttöä. Noudata käyttöohjeita tarkasti ja säilytä ne myöhempää tarvetta varten.
- PL: WAŻNE INFORMACJE.**
Przed użyciem produktu należy dokładnie zapoznać się ze wskazówkami bezpieczeństwa. Należy zapoznać się z instrukcją obsługi i zachować ją do użytku w przyszłości.
- CZ: DŮLEŽITÉ INFORMACE!**
Před sestavením nebo použitím výrobku si pečlivě přečtěte celý návod. Dodržujte důsledně uvedené pokyny a návod uschovejte, aby byl k dispozici v případě potřeby.
- HU: FONTOS INFORMÁCIÓ**
A termék összeszerelésének vagy használatának megkezdése előtt figyelmesen olvassa el a teljes útmutatót. Őrizze meg az útmutatót, és gondosan tartsa be a benne foglaltakat.
- SK: DŮLEŽITÉ INFORMÁCIE!**
Predtým ako začnete s montážou a/alebo používaním tohto produktu si pozorne prečítajte celý návod. Návod dôsledne dodržiavajte a ponechajte si ho pre použitie v budúcnosti.
- NL: BELANGRIJKE INFORMATIE!**
Lees de volledige handleiding zorgvuldig door voordat u dit product monteert en/of gebruikt. Volg de handleiding zorgvuldig en bewaar deze voor toekomstig gebruik.
- SI: POMEBNE INFORMACIJE!**
Pred montažo/porabo izdelka pozorno preberite ta navodila za uporabo. Upošteвайте navodila in jih shranite, saj jih boste morda še potrebovali.
- RU: ВАЖНАЯ ИНФОРМАЦИЯ!**
Внимательно и полностью прочитайте это руководство, прежде чем приступать к сборке или использованию этого изделия. Следуйте всем инструкциям этого руководства и сохраните его на будущее для справки.
- HR: VAŽNE OBAVJESTI!**
Molimo Vas pažljivo pročitajte upute za uporabu prije sastavljanja i/ili korištenja ovog proizvoda. Strogo se pridržavajte uputa i sačuvajte ih za buduće potrebe.
- BA: VAŽNE INFORMACIJE!**
Prije sklapanja i/ili korištenja ovog proizvoda, pažljivo pročitajte cijeli priručnik. Pažljivo se pridržavajte uputstava u priručniku i sačuvajte ga za buduće upotrebu.
- CN: 重要信息!**
组装前或使用本产品之前请通读该手册。请严格遵循手册说明，保留手册供日后参考。
- RS: VAŽNE INFORMACIJE!**
Pažljivo pročitajte kompletan priručnik pre nego što počnete da sklapate i/ili koristite ovaj proizvod. Detaljno sledite priručnik i sačuvajte ga za kasniju upotrebu.
- UA: ВАЖЛИВА ІНФОРМАЦІЯ.**
Уважно прочитайте весь посібник, перш ніж збирати та/чи використовувати цей продукт. Виконайте всі інструкції цього посібника та збережіть його для подальшого використання.
- RO: INFORMAȚII IMPORTANTE**
Citiți cu atenție întregul manual înainte de a începe să montați și/sau să utilizați acest produs. Urmați îndeaproape instrucțiunile din manual și păstrați-l pentru consultare ulterioară.
- BG: ВАЖНА ИНФОРМАЦИЯ!**
Моля, прочетете цялото ръководство внимателно, преди да започнете да сглобявате и/или използвате този продукт. Следвайте стриктно ръководството и го пазете за бъдещи справки.
- GR: ΣΗΜΑΝΤΙΚΕΣ ΠΛΗΡΟΦΟΡΙΕΣ!**
Διαβάστε προσεκτικά ολόκληρο το εγχειρίδιο πριν από τη συναρμολόγηση ή/και τη χρήση του προϊόντος. Ακολουθήστε προσεκτικά τις οδηγίες του εγχειριδίου και κρατήστε τις για μελλοντική αναφορά.
- TR: ÖNEMLİ BİLGİLER!**
Bu ürünün montajına/yapmaya başlamadan ve/veya ürünü kullanmadan önce lütfen kılavuzun tamamını dikkatlice okuyun. Kılavuzu adan adan izleyin ve daha sonra başvurmak üzere saklayın.
- FR: INFORMATIONS IMPORTANTES**
Veuillez lire attentivement l'ensemble du manuel avant de commencer à monter et/ou utiliser ce produit. Suivez rigoureusement le manuel et conservez-le pour toute consultation ultérieure.

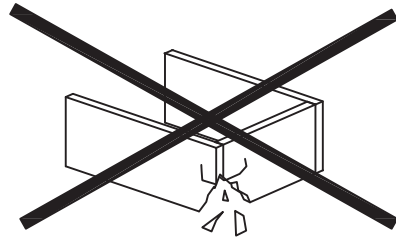
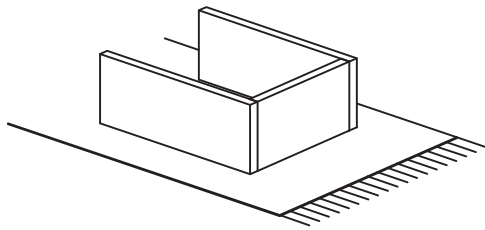

- GB: WARNING TO AVOID SCRATCHES!**
In order to avoid scratching this furniture should be assembled on a soft layer - could be a rug.
- DK: ADVARSEL FOR AT FORHINDRE RIDSER!**
For at forhindre ridser skal dette møbel samles på et blødt underlag, f.eks. et tæppe.
- SE: VARNING OM HUR DU UNDVIKER REPOR!**
För att undvika repor ska denna möbel monteras på ett mjukt underlag, exempelvis en matta.
- NO: ADVARSEL FOR Å UNNGÅ RIPER!**
For å unngå riper må møbelet monteres på et mykt underlag, for eksempel et teppe.
- FI: VARO NAARMUJA!**
Varo naarmuja ja kokoa tämä kaluste pehmeällä alustalla, esimerkiksi maton päällä.
- PL: OSTRZEŻENIE WS. USZKODZEŃ**
Aby uniknąć rys, ten mebel powinien być montowany, składany na miękkim podłożu, np. dywanie.
- CZ: VAROVÁNÍ TYKAJÍCÍ SE POŠKRÁBÁNÍ!**
Aby nedošlo k poškrábání, sestavujte nábytek na měkkém podkladu – např. na koberci.
- HU: KARCOLÁSOK MEGELŐZÉSE – FIGYELEM!**
A karcolások megelőzése érdekében a bútort puha felületen, például szőnyegen kell összeszerelni.
- SK: VÝSTRAHA TYKAJÚCA SA PREDCHÁDZANIA ŠKRABANCOM!**
Aby sa predišlo škrabancom, tento nábytok by sa mal montovať na mäkkom podklade, napríklad na koberci.
- NL: WAARSCHUWING OM KRASSEN TE VERMIJDEN!**
Om te voorkomen dat dit meubel krassen vertoont, moet het gemonteerd worden op een zachte ondergrond - zoals een tapijt
- SI: KAKO PREPREČITI PRASKE!**
Da bi se izognili praskam na pohištvu, pohištvu sestavite na mehki podlagi, npr. na preprogi
- RU: ПРЕДУПРЕЖДЕНИЕ ОТНОСИТЕЛЬНО ЦАРАПИН!**
Во избежание нанесения царапин, сборку этой мебели необходимо выполнять на мягкой поверхности, например на ковре.
- HR: UPOZORENJE O IZBJEGAVANJU OGREBOTINA!**
Kako bi se izbjegle ogrebotine, ovaj proizvod potrebno je sastavljati na mekanoj površini - primjerice, na tepihu.
- BA: UPOZORENJE ZA SPRJEČAVANJE NASTANKA OGREBOTINA!**
Da bi se izbjegle ogrebotine na ovom namještaju, poželjno ga je sastaviti na mekoj podlozi - na primjer, tepihu.
- CN: 防刮警告!**
为了避免刮伤家具，应在地毯等软面上进行组装。
- RS: UPOZORENJE ZA IZBEGAVANJE OGREBOTINA!**
Da biste izbegli ogrebotine, ovaj nameštaj treba da sastavljate na mekoj podlozi - može prostirka.
- UA: ПОПЕРЕДЖЕННЯ ЩОДО ПОДРЯПИН.**
Щоб уникнути подряпин, ці меблі слід збирати на м'якій поверхні, наприклад, на килимі.
- RO: ATENȚIONARE PENTRU EVITAREA ZGĂRIERII!**
Pentru evitarea zgărierii, această piesă de mobilier trebuie să fie montată pe o suprafață moale, de exemplu, pe un covor.
- BG: ПРЕДУПРЕЖДЕНИЕ ЗА ИЗБЯГВАНЕ НА ДРАСКОТИНИ!**
За да избегнете надраскване, тази мебел трябва да бъде сглобена на мека повърхност – например килим.
- GR: ΠΡΟΕΙΔΟΠΟΙΗΣΗ ΓΙΑ ΤΗΝ ΑΠΟΦΥΓΗ ΓΡΑΤΣΟΥΝΙΩΝ!**
Για την αποφυγή γρατσουνιών, το έπιπλο θα πρέπει να συναρμολογηθεί σε μαλακή επιφάνεια, όπως για παράδειγμα πάνω σε ένα χαλί.
- TR: ÇİZİLMELERİ ÖNLEMEYE YÖNELİK UYARI!**
Bu mobilyanın çizilmesini engellemek için montajını yumuşak bir yüzeyin üzerinde yapın.
- FR: AVERTISSEMENT POUR ÉVITER LES RAYURES**
Afin d'éviter les rayures, ce meuble doit être monté sur une surface souple (un tapis, par exemple).

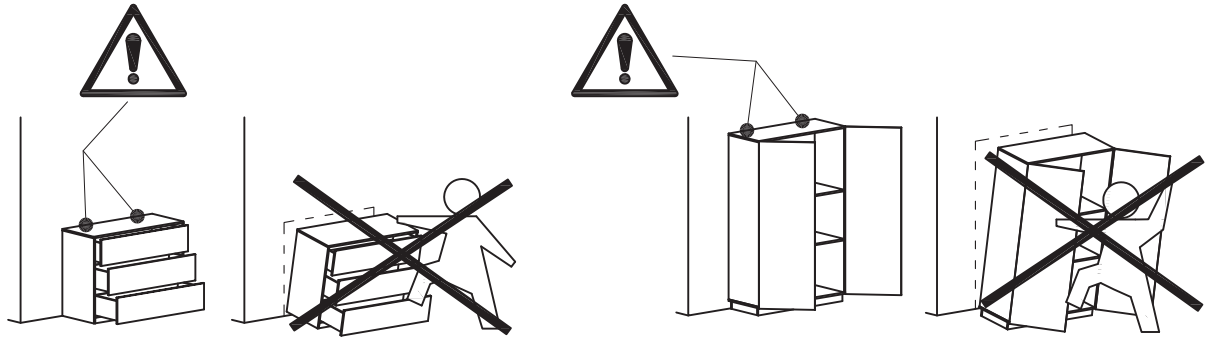

GB: ANTI-TOPPLE WARNING!

This product has to be permanently fixed to the wall with the bracket(s) included, to avoid fatal injury in case it topples over. The pack only contains screws for fastening the anti-topple bracket(s) itself to the product. Please contact your DIY or hardware store for advice on the correct type of screws/raw plugs for your type of wall.

DK: ADVARSEL VEDRØRENDE VÆLTESIKRING!

Dette produkt skal fastgøres permanent til væggen med det eller de medfølgende beslag for at forhindre livsfarlige skader, hvis produktet vælter. Pakken indeholder kun skruer til fastgørelse af væltesikringsbeslaget eller -beslagene til selve produktet. Kontakt dit lokale byggemarked eller din isenkræmmer for vejledning om den korrekte type af skruer/rawplugs til netop din type væg.

SE: TIPP-VARNING!

Denna produkt måste fästas vid väggen med bifogat fäste/bifogade fästen för att undvika att den tippar och faller över ända, och på så sätt orsakar allvarliga personskador inklusive dödsfall. Förpackningen innehåller endast skruvar för fästsättning av fästet/fästena på produkten. Kontakta en järnaffär eller ett byggvaruhus för råd om rätt typ av skruv/plugg för den typ av vägg du har.

NO: ADVARSEL, VELTEFARE!

Dette produktet må festes permanent til veggen med medfølgende braket(er) for å hindre at det velter og forårsaker skade. Pakken inneholder bare skruer for å feste veltesikringsbraketter(e) til produktet. Rådfør deg med en jernvarehandel for å finne egnede skruer/plugger til den aktuelle veggen.

FI: KAATUMISVAARA!

Tämä tuote on kiinnitettävä seinään mukana toimitetuilla kiinnikkeillä kohtalokkaiden vammojen välttämiseksi tuotteen mahdollisesti kaatuessa. Pakkaus sisältää vain kiinnitysruuvit kaatumista estävien kiinnikkeiden kiinnittämiseksi tuotteeseen. Rautakaupasta saa lisätietoja seinämateriaalin vaatimista ruuveista ja tulpista.

PL: OSTRZEŻENIE PRZED WYWRÓCENIEM SIĘ

Produkt musi być na stałe przymocowany do ściany dołączonymi uchwytami, aby uniknąć śmiertelnego wypadku, gdy się przewróci. W pakiecie są tylko śruby pozwalające na przykręcenie uchwytów do produktu, które zapobiegają przewróceniu się produktu. Prosimy o skontaktowanie się ze specjalistycznym sklepem lub fachowcem w sprawie śrub lub kołków, które należy zastosować do danego typu ściany.

CZ: VAROVÁNÍ TÝKAJÍCÍ SE SKLOPENÍ!

Tento výrobek musí být trvale připevněn na stěnu pomocí přiložených držáků, aby nedošlo ke smrtelnému zranění, kdyby se sklopil. Sada obsahuje pouze šroubky pro upevnění držáků zabráňujících sklopení k výrobku. Ohledně správného typu vrutů/hmoždínek pro daný typ stěny se obraťte na vhodný obchod nebo železářství.

HU: BORULÁS VESZÉLYE – FIGYELEM!

A termékét fixen rögzíteni kell a falhoz a mellékelt tartóelem(ek) segítségével. Ellenkező esetben halálos sérülést okozhat, ha felborul. A csomag csak a borulásgátló tartóelem(ek)nek a termékhez való rögzítésére szolgált csavarokat tartalmazza. Érdeklődjön a DIY boltban vagy egy barkácsboltban, hogy milyen a megfelelő csavar, illetve tipli az adott faltípushoz.

SK: VÝSTRAHA PRED PREVRÁTENÍM!

Tento produkt musí byť natrvalo pripevnený k stene pomocou dodanej(ých) konzoly (konzol), aby sa predišlo smrtelnému úrazu v prípade, že sa prevráti. Balenie obsahuje iba skrutky, ktorými sa pripevňujú k produktu samotné konzoly chrániace pred prevrátaním. Kontaktujte miestnu predajňu pre domácich majstrov alebo železiarstvo, kde vám poradia ohľadom správneho typu skrutiek/prichytkiek pre váš typ steny.

NL: WAARSCHUWING KANTELBEVEILIGING!

Dit product moet met de haak/haken permanent bevestigd worden aan de muur om verwondingen met dodelijke afloop te voorkomen indien deze omkantelt. De verpakking bevat enkel schroeven om de haken voor kantelbeveiliging op het product vast te maken. Contacteer uw doe-het-zelfzaak of bouwmarkt voor advies over het correcte type schroeven/rawplugs voor uw soort muur.

SI: OPOZORILO O ZAŠČITI PRED PREVRNITVIJO!

Ta izdelek je treba s priloženimi nosilci trajno pritrditi na steno, da se izognete smrtnim poškodbam v primeru prevrnitve izdelka. Paket vsebuje le vijake za pritrditev zaščitnih nosilcev na izdelek. Strokovnjaka ali trgovino z opremo za dom povprašajte za nasvet glede pravilnega tipa vijakov/zidnih vložkov, ki so najbolj primerni za uporabo na vaši steni.

RU: ПРЕДУПРЕЖДЕНИЕ ОБ ОПРОКИДЫВАНИИ!

Во избежание опрокидывания это изделие должно быть надежно прикреплено к стене с помощью прилагаемых кронштейнов. В комплект входят винты только для прикрепления кронштейнов к самому изделию. Шурупы и дюбели для крепления к стене конкретного типа можно найти в строительном или хозяйственном магазине.

HR: UPOZORENJE O ZAŠTITI OD PREVRTANJA!

Proizvod mora biti trajno učvršćen na zid s pomoću isporučenih nosača kako bi se u slučaju izbjegle smrtonosne ozljede. S proizvodom se isporučuju samo vijci za pričvršćavanje zaštitnih nosača na proizvod. Molimo Vas da od svog prodavača zatražite savjet o vrsti vijaka/tipli koje su najprikladnije za Vaš zid.

BA: UPOZORENJE ZA SPRJEČAVANJE PREVRTANJA!

Ovaj proizvod je potrebno trajno fiksirati na zid koristeći priloženi nosač(e), kako bi se izbjegle ozbiljne ozljede u slučaju njegovog prevrtanja. U pakovanju su priloženi samo vijci za pričvršćavanje nosača na proizvod. Savjet vezano za vijke/tiple prikladne za vaš zid, potražite u lokalnoj DIY trgovini ili željezariji.

CN: 防翻倒警告!

本产品必须使用提供的支架固定到墙上，以免翻倒造成致命伤害。产品包装内只含有将防翻倒支架与产品固定在一起的螺钉。请与 DIY 或五金店联系，咨询适合您墙面的螺钉/螺帽。

RS: UPOZORENJE O OPASNOSTI OD PADA!

Ovaj proizvod mora stalno da bude pričvršćen za zid držačem (držačima) iz pakovanja, da bi se izbegla smrtonosna povreda u slučaju da proizvod padne. Pakovanje sadrži samo šrafove za pričvršćavanje na proizvod držača protiv padanja. Kontaktirajte prodavnicu "Uradj sam" ili gvozdarsku radnju za savet o ispravnoj vrsti šrafova/tiplova za tip zida koji imate.

UA: ПОПЕРЕДЖЕННЯ ЩОДО ПЕРЕКИДАННЯ ПРОДУКТУ.

Цей продукт необхідно надійно прикріпити до стіни за допомогою кронштейнів, що входять до комплекту поставки. Це дозволить запобігти важких травмувань у разі перекидання продукту. До комплекту входять тільки гвинти для кріплення до продукту кронштейнів, що запобігають падінню. Зверніться до співробітників магазину побутових товарів або обладнання, щоб підібрати правильний тип гвинтів/дюбелів, які підходять до ваших стін.

RO: ATENȚIONARE PENTRU PREVENIREA RĂSTURNĂRII!

Produsul trebuie fixat permanent pe perete cu ajutorul suporturilor incluse, pentru evitarea accidentărilor fatale, în cazul în care acesta se răstoarnă. Pachetul conține numai șuruburile necesare pentru fixarea pe perete a suporturilor pentru prevenirea răsturnării. Contactați magazinul de bricolaj sau de articole de mobilier pentru sfaturi referitoare la tipul corect de șuruburi/diabluri pentru tipul dvs. de perete.

BG: ПРЕДУПРЕЖДЕНИЕ ПРОТИВ ПАДАНЕ!

Този продукт трябва да бъде трайно монтиран на стената с помощта на включената скоба (или скоби), за да се избегнат смъртоносни наранявания, в случай че той падне. Пакетът съдържа само винтове за фиксиране на скобата (или скобите) против падане за продукта. Моля, попитайте в магазин за бита или железарски магазин за съвет относно подходящия тип винтове/дюбели за вашия тип стена.

GR: ΠΡΟΕΙΔΟΠΟΙΗΣΗ ΣΥΓΚΡΑΤΗΣΗΣ!

Το προϊόν πρέπει να είναι πάντοτε στερεωμένο στον τοίχο, με τα στηρίγματα που παρέχονται, για την αποφυγή σοβαρού τραυματισμού σε περίπτωση ανατροπής. Στη συσκευασία περιέχονται μόνο βίδες για τη στερέωση των στηρίγμάτων συγκράτησης του προϊόντος. Για βοήθεια σχετικά με τις βίδες/βύσματα που είναι κατάλληλα για τον τοίχο σας, απευθυνθείτε σε κάποιον ειδικό ή σε κατάστημα τέτοιων υλικών.

TR: DEVRİLMEME KARŞI KORUYUCU DESTEĞE YÖNELİK UYARI!

Devrilip düşme sonucu ortaya çıkabilecek ölümcül yaralanmaların önlemek üzere bu ürün, devrilmeye karşı koruyucu destekleriyle birlikte duvara kalıcı olarak şekilde sabitlenmelidir. Pakette yalnızca devrilip düşmeye karşı koruyucu desteği ürüne sabitleyecek vidalar bulunmaktadır. Duvarın zeminine özgü vida/dübel tiplerine ilgili doğru bilgi için lütfen yapı marketinize veya nalbur dükkanınıza danışın.

FR: AVERTISSEMENT ANTIBASCULEMENT

Ce produit doit être fixé de manière permanente au mur à l'aide du/des support(s) inclus afin d'éviter des blessures mortelles en cas de basculement. L'emballage contient des vis pour attacher le(s) support(s) antibasculement au produit. Veuillez contacter votre magasin de bricolage ou votre quincaillerie pour obtenir des conseils sur le type de vis/chevilles adapté à votre mur.

- GB: IMPORTANT!**
It is important that any product which is assembled using any kind of screw is re-tightened 2 weeks after assembly, and once every 3 months - in order to assure stability through-out the lifespan of the product.
- DK: VIGTIGT!**
Det er vigtigt, at alle produkter, der samles med alle former for skruer, efterspændes to uger efter samling samt hver tredje måned for at sikre, at produktet er stabilt i hele dets levetid.
- SE: VIKTIGT!**
För alla produkter som monteras med skruv är det viktigt att dessa efterdras två veckor efter monteringen och därefter en gång var tredje månad. Detta för att säkerställa att produkten håller sig stabil under hela sin livslängd.
- NO: VIKTIG!**
Det er viktig at alle produkter som monteres med skruer blir etterstrammet 2 uker etter montering, og hver 3. måned for å sikre stabiliteten gjennom hele produktets levetid
- FI: TÄRKEÄÄ!**
On tärkeää, että kaikki ruuvien avulla koottavat tuotteet kiristetään uudelleen 2 viikkoa kokoamisen jälkeen ja aina 3 kuukauden välein, jotta tuote pysyy vakaana koko käyttöikänsä ajan.
- PL: WAŻNE!**
Ważne jest, żeby każdy ze skręcanych produktów został ponownie dokręcony w ciągu 2 tygodni od montażu, a następnie sprawdzać co 3 miesiące czy śruby są dokręcone — w celu zapewnienia stabilności przez czas użytkowania produktu.
- CZ: DŮLEŽITÉ!**
U každého výrobku, který se sestavuje pomocí jakýchkoli šroubků, je důležité dotáhnout šroubky 2 týdny po sestavení a potom každé 3 měsíce, aby byla zajištěna stabilita po celou dobu životnosti výrobku.
- HU: FONTOS!**
Minden terméknél fontos, hogy bármilyen fajta csavarral is történi az összeszerelése, utána 2 héttel, majd 3 havi rendszerességgel szükséges a csavarok utánhúzása. Ezzel a termék teljes élettartamán keresztül biztosítható a stabilitása.
- SK: DŮLEŽITÉ!**
Je důležité, aby sa na akomkoľvek produkte, montovanom pomocou akýchkoľvek skrutiek, skrutky dotiahli po dvoch týždňoch od montáže, a jedenkrát v priebehu každých 3 mesiacov – tak sa zaručí stabilita počas celej životnosti produktu.
- NL: BELANGRIJK!**
Het is belangrijk om elk product dat met om het even welk soort schroef wordt gemonteerd, twee weken na montage en om de drie maanden, opnieuw wordt vastgeschroefd, om de stabiliteit van het product tijdens de hele levensduur te verzekeren.
- SI: POMEMBNO!**
Vsak izdelek, ki ga sestavite z uporabo kakršnihkoli vijakov morate 2 tedna po sestavitvi ponovno pregledati in vijake po potrebi priviti. To ponovite vsake 3 mesece, da bi zagotovili stabilnost izdelka skozi njegovo celotno življenjsko dobo.
- RU: ВАЖНО!**
В любом изделии, собранном с использованием винтов любого типа, необходимо через 2 недели после сборки и в дальнейшем каждые 3 месяца подтягивать винты, чтобы обеспечить прочность изделия в течение срока эксплуатации.
- HR: VAŽNO!**
Važno je da se svi tipovi vijaka na bilo kojoj vrsti proizvoda koji se s pomoću njih sastavlja ponovno pritegnu 2 tjedna nakon sastavljanja te jednom svaka 3 mjeseca - kako bi se zajamčila stabilnost tijekom životnog vijeka proizvoda.
- BA: VAŽNO!**
Za sve proizvode sa vijčanim vezama, potrebno je izvršiti pritezanje 2 sedmice nakon sklapanja i svaka 3 mjeseca nakon toga, kako bi se osigurala stabilnost tokom cijelog životnog vijeka proizvoda.
- CN: 重要提示!**
使用任何类型的螺钉组装的产品，必须在组装 2 周后重新拧紧，并且每 3 个月重新拧紧一次，以确保产品在整个使用期内结实稳固。
- RS: VAŽNO!**
Važno je da svaki proizvod koji je sklopljen korišćenjem bilo kakvih šrafova bude ponovo pričvršćen 2 nedelje nakon sklapanja i jednom svaka 3 meseca - kako bi se obezbedila stabilnost tokom celog veka trajanja proizvoda.
- UA: УВАГА.**
Майте на увазі, якщо у процесі монтажу продукту використовуються гвинти будь-якого типу, їх треба повторно затягнути через 2 тижні після монтажу, а потім кожні 3 місяці. Це необхідно для того, щоб забезпечити надійне використання продукту протягом терміну його служби.
- RO: IMPORTANT!**
Este important ca șuruburile de orice tip, cu ajutorul cărora au fost montate produsele, să fie strânse din nou la 2 săptămâni după montare și, apoi, o dată la 3 luni, pentru a se asigura stabilitatea de-a lungul duratei de viață a produsului
- BG: ВАЖНО!**
Важно е всеки продукт, който е сглобен с помощта на винтове, да бъде затегнат 2 седмици след сглобяването, и веднъж на всеки 3 месеца, за да се гарантира стабилност през цялото време на използване на продукта.
- GR: ΣΗΜΑΝΤΙΚΟ!**
Για κάθε προϊόν που συναρμολογείται με βίδες είναι σημαντικό αυτές να ξανασφίγγονται 2 εβδομάδες μετά τη συναρμολόγηση και μία φορά κάθε 3 μήνες, για τη διασφάλιση της σταθερότητας σε όλη τη διάρκεια ζωής του προϊόντος.
- TR: ÖNEMLİ!**
Vida kullanılarak yapılan her türlü ürün montajının montajdan 2 hafta sonra vidaların yeniden sıkılması ve kullanılm süresi boyunca ürünün istikrarlı ve sağlamlaşması için de her 3 ayda bir vidaların sıkılması önem arz eder.
- FR: IMPORTANT**
Il est important que tout produit monté à l'aide de vis soit resserré 2 semaines après son montage, puis tous les 3 mois, afin de garantir sa stabilité durant tout son cycle de vie.



- GB: GENERAL INSTRUCTION FOR FURNITURE MADE OF WOOD OR WOOD COMPOSITES SUCH AS MELAMINE, LAMINATE OR VENEER SURFACES!**
Wipe clean with a damp cloth. Use only water or a gentle detergent.
Wipe dry with a clean cloth.
- DK: GENEREL VEJLEDNING TIL MØBLER FREMSTILLET AF TRÆ ELLER TRÆKOMPOSITMATERIALER SOM MELAMIN, LAMINAT ELLER FINER!**
Rengøres med en fugtig klud. Anvend endast vand eller et mildt rengøringsmiddel.
Tørres af med en ren klud.
- SE: ALLMÄNNA INSTRUKTIONER GÄLLANDE MÖBLER AV TRÄ ELLER TRÄKOMPOSIT SÅSOM MELAMIN, LAMINAT ELLER FANER!**
Torka rent med en fuktig trasa. Använd endast vatten eller ett mildt rengöringsmedel. Torka torrt med en ren trasa.
- NO: GENERELLE INSTRUKSJONER FOR MØBLER LAGET AV TRE ELLER TREKOMPOSITT SOM MELAMIN, LAMINAT ELLER FINER!**
Tørk av med en fuktig klut. Bruk bare vann eller et mildt vaskemiddel.
Tørk av med en ren klut.
- FI: YLEISIÄ OHJEITA PUUSTA JA PUUKOMPOSIITTIMATERIAALEISTA KUTEN MELAMIINISTA, LAMINAATISTA TAI VANERISTA VALMISTETUIILLE KALUSTEILLE!**
Pyyhi puhtaaksi kostealla liinalla. Käytä vain vettä tai mietoä pesuainetta.
Kuivaa puhtaalla liinalla.
- PL: OGÓLNE INSTRUKCJE DOTYCZĄCE MEBLI Z DREWNA ORAZ MATERIAŁÓW DREWNOPOCHODNYCH: MELAMINA, LAMINAT, OKLEINA**
Do czyszczenia należy używać wilgotnej ściereczki. Używać wyłącznie wody lub delikatnego detergentu.
Wycierać do sucha ściereczką.
- CZ: OBECNÉ POKYNY TYKAJÍCÍ SE NÁBYTKU VYROBENÉHO ZE DŘEVA NEBO Z KOMPOZITŮ DŘEVA, NAPŘ. S POVRCHEM Z MELAMINU, LAMINÁTU NEBO DÝHY!**
Čistěte otřením navlhčeným hadříkem. Používejte pouze vodu nebo jemný čistící prostředek.
Vytřete dosucha čistým hadříkem.
- HU: ÁLTALÁNOS ÚTMUTATÁS A FÁBÓL KÉSZÜLT VAGY ÖSSZETETT FAANYAGOT, PÉLDÁUL MELAMIN-, LAMINÁLT VAGY FURNÉRFELÜLETET TARTALMAZÓ BÚTOROKHOZ**
Törölje tisztára nedves ruhával. Csak vizet vagy kímélő tisztítószert használjon.
Törölje szárazra tiszta ruhával.
- SK: VŠEOBECNÉ POKYNY PRE NÁBYTKOVÝ VYROBENÝ Z DREVA ALEBO KOMPOZITNÝCH MATERIÁLOV, NAPRIKĽAD MELAMÍNU, LAMINÁTU ALEBO PREGLEJKOVÝCH POVRCHOV!**
Utrite dočista navlhčenou utierkou. Používajte iba vodu alebo jemný čistiaci prostriedok.
Utrite dosucha čistou utierkou.
- NL: ALGEMENE INSTRUCTIES VOOR MEUBELS VERVAARDIGD UIT HOUT OF HOUTCOMPOSIT ALS MELAMINE, LAMINAAT OF FINEEROPPERVLAKKEN!**
Reinig met een vochtige doek. Gebruik alleen water of wasmiddel.
Droogwrijven met een schone doek
- SI: SPLOŠNA NAVODILA ZA VZDRŽEVANJE POHIŠTVA IZ LESA ALI LESENIH KOMPOZITOV, KOT SO MELAMIN, LAMINAT ALI FURNIR!**
Obrišite z vlažno krpo. Uporabljajte le vodo ali blagi detergent.
Posušite s čisto krpo
- RU: ОБЩИЕ УКАЗАНИЯ ОТНОСИТЕЛЬНО МЕБЕЛИ, ИЗГОТОВЛЕННОЙ ИЗ ДЕРЕВА ИЛИ ДРЕВЕСНЫХ КОМПОЗИЦИОННЫХ МАТЕРИАЛОВ, ТАКИХ КАК МЕЛАМИН, ЛАМИНАТ ИЛИ ШПОН!**
Очистите изделие чистой влажной тканью. Используйте мягкодействующее моющее средство.
Вытрите досуха чистой тряпкой.
- HR: OPĆE UPUTE ZA NAMJEŠTAJ IZRAĐEN OD DRVA ILI DRVNIH KOMPOZITA, KAO ŠTO SU POVRŠINE OD MELAMINA, LAMINATA ILI FURNIRA!**
Očistite vlažnom krpom. Upotrijebite samo vodu ili blagi deterđent.
Posušite čistom krpom.
- BA: OPŠTA UPUTSTVA ZA NAMJEŠTAJ OD DRVETA ILI DRVENIH KOMPOZITA, NA PRIMJER ZA POVRŠINE OD MELAMINA, LAMINATA ILI FURNIRA.**
Obrišati vlažnom krpom. Koristiti samo vodu ili blagi deterđent.
Posušiti suhom krpom.
- CN: 针对实木及实木复合类（三聚氰胺面、层板、胶合板）家具的一般说明**
请用湿布擦拭。只使用水或温和洗涤剂。
请用干净的布擦干。
- RS: OPŠTA UPUTSTVA ZA NAMEŠTAJ NAPRAVLJEN OD DRVETA ILI DRVENOG KOMPOZITA KAO ŠTO SU MELAMIN, LAMINAT ILI FURNIR POVRŠINE!**
Obrišite vlažnom krpom. Koristite samo vodu ili blagi deterđent.
Prebršite suvom, čistom krpom.
- UA: ЗАГАЛЬНА ІНСТРУКЦІЯ ДЛЯ МЕБЛІВ, ВИГОТОВЛЕНИХ З ДЕРЕВА ЧИ ДЕРЕВ'ЯНИХ КОМПОНЕНТІВ, НАПРИКЛАД, МЕЛАМІНУ, ЛАМІНАТА АБО ШПОНУ.**
Протирайте за допомогою вологої ганчірки. Використовуйте воду або слабкий розчин миючого засобу.
Витирайте чистою ганчіркою.
- RO: INSTRUCȚIUNI GENERALE PENTRU PIESELE DE MOBILIER REALIZATE DIN LEMN SAU DIN COMPUȘI DIN LEMN PRECUM SUPRAFEȚELE MELAMINATE, LAMINATE SAU FURNIRUTE!**
Curățați prin ștergere cu o lavetă umedă. Utilizați numai apă sau un detergent delicat.
Uscați prin ștergere cu o lavetă curată.
- BG: ОБЩА ИНСТРУКЦИЯ ЗА МЕБЕЛИ, ИЗРАБОТЕНИ ОТ ДЪРВО ИЛИ ДЪРВЕНИ КОМПОЗИТНИ МАТЕРИАЛИ, КАТО МЕЛАМИН, ЛАМИНАТ ИЛИ ФУРНИРНИ ПОВЪРХНОСТИ!**
Избършете с влажна кърпа. Използвайте само вода или лек почистващ препарат.
Подсушете с чиста кърпа.
- GR: ΓΕΝΙΚΕΣ ΟΔΗΓΙΕΣ ΓΙΑ ΕΠΙΠΛΑ ΑΠΟ ΞΥΛΟ Ή ΣΥΝΘΕΤΙΚΟ ΞΥΛΟ ΟΠΩΣ ΜΕΛΑΜΙΝΗ, ΛΑΜΙΝΕΪΤ Ή ΛΟΥΣΤΡΑΡΙΣΜΕΝΕΣ ΕΠΙΦΑΝΕΙΕΣ!**
Σκουπίστε με ένα υγρό πανί. Χρησιμοποιείτε μόνο νερό ή ένα απαλό απορροπαντικό.
Στεγνώνετε με ένα καθαρό πανί.
- TR: AHŞAP VEYA MELAMİN, LAMİNAT YA DA AHŞAP KAPLAMA GİBİ AHŞAP TÜREVİ YÜZEYLERDEN YAPILAN MOBİLYALARA YÖNELİK GENEL YÖNERGE!**
Nemli bir bezle silerek temizleyin. Yalnızca su veya yumuşak bir deterjan kullanın.
Temiz bir bezle silerek kurulayın.
- FR: INSTRUCTIONS GÉNÉRALES POUR LE MOBILIER CONSTITUÉ DE BOIS OU DE COMPOSITES DE BOIS (COMME LES SURFACES EN MELAMINÉ, STRATIFIÉ OU PLACAGE)**
Nettoyer à l'aide d'un chiffon humide. Utiliser uniquement de l'eau ou un détergent doux.
Essuyer à l'aide d'un chiffon propre.

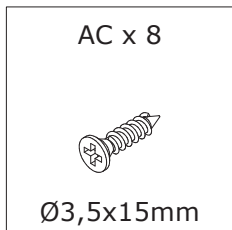
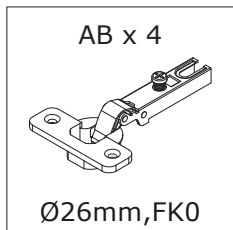
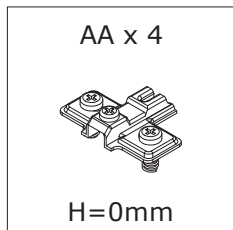
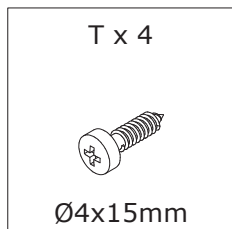
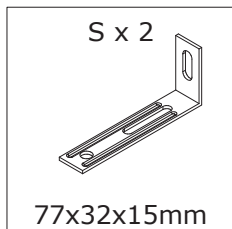
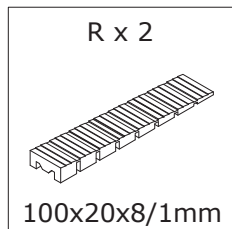
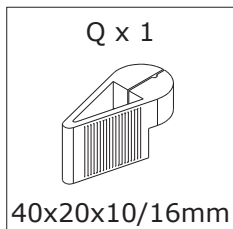
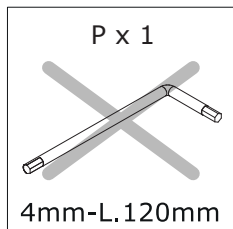
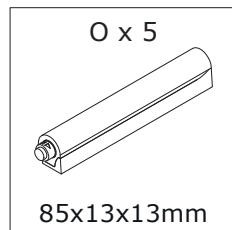
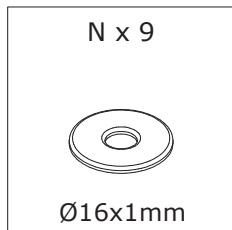
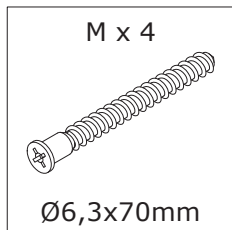
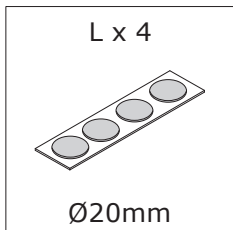
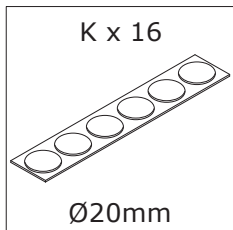
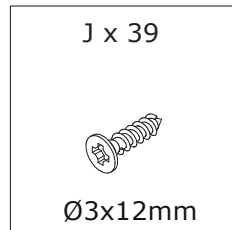
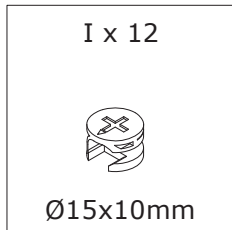
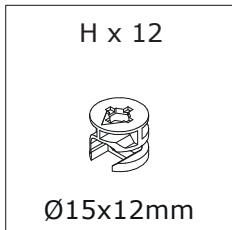
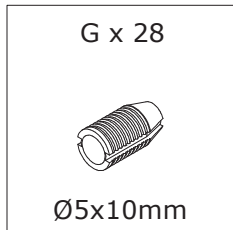
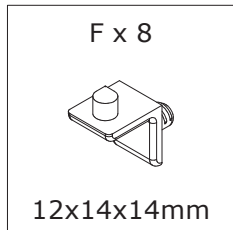
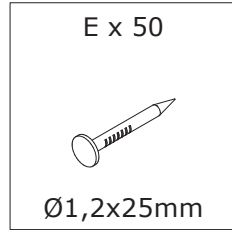
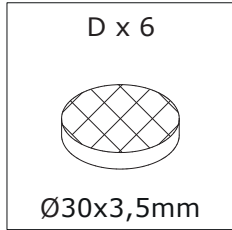
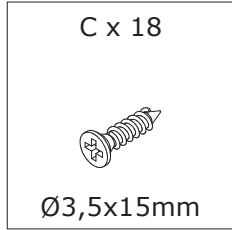
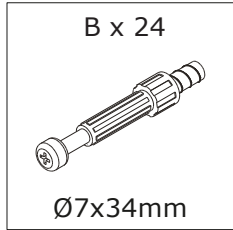
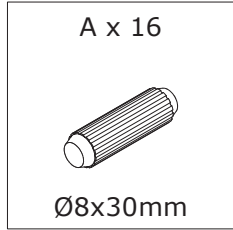
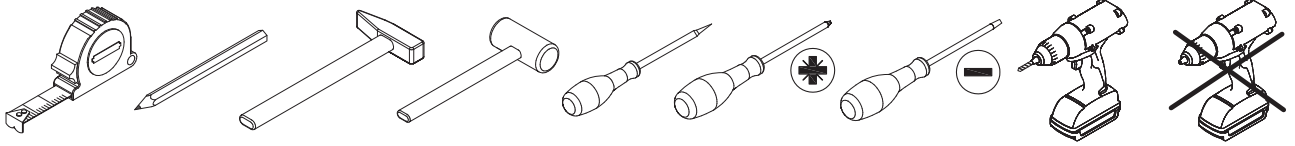

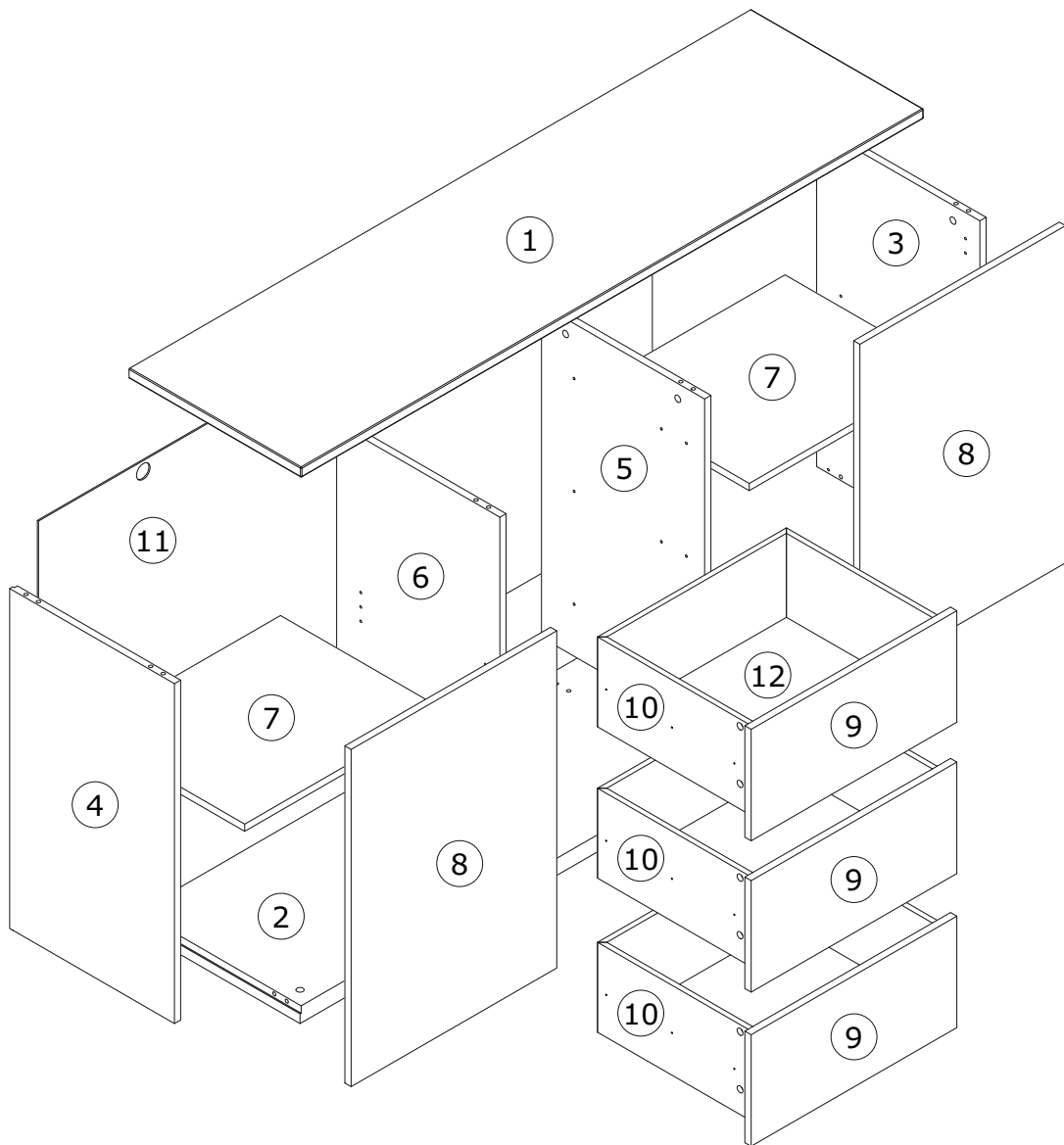

Box 1/2

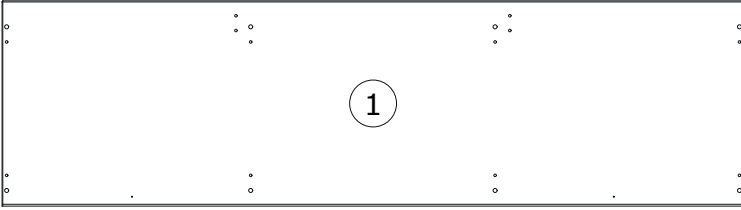

1598x442x22mm

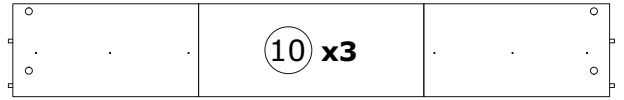

400x485x400mm H.200mm

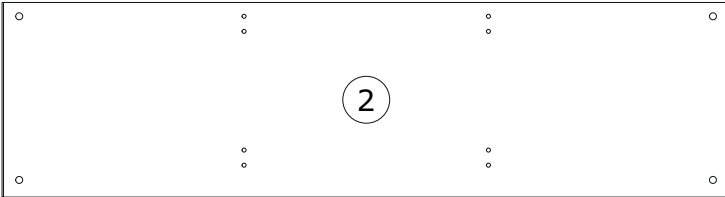

1568x419x38mm

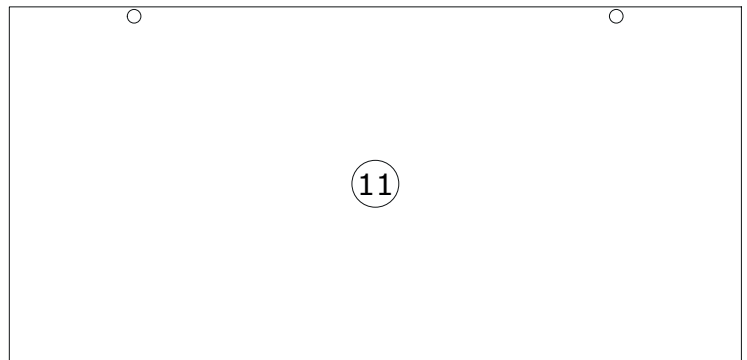

1576x762x2mm

Box 2/2

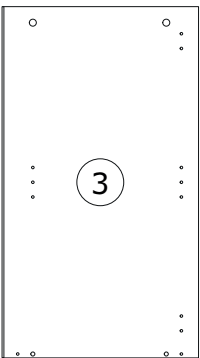

756x423x16mm

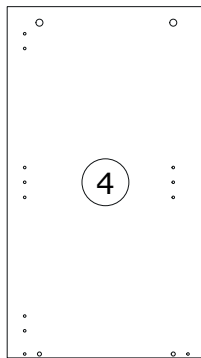

756x423x16mm

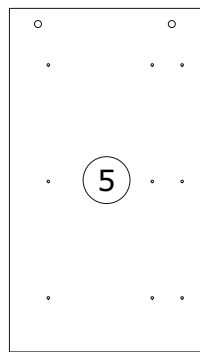

740x419x16mm

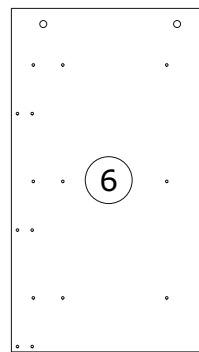

740x419x16mm

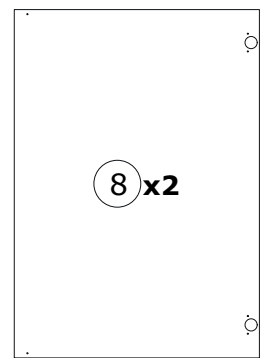

750x528x16mm

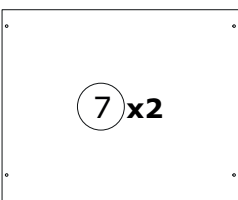

510x418x16mm

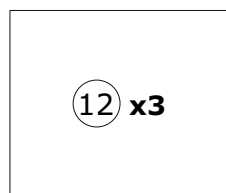

472x401x2mm

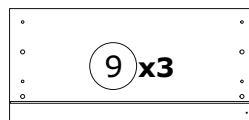

528x248x16mm

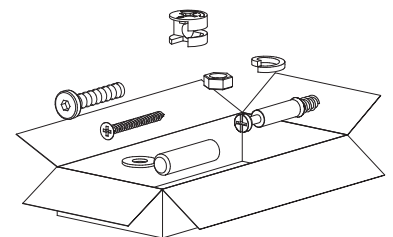

1

B x 8
Ø7x34mm

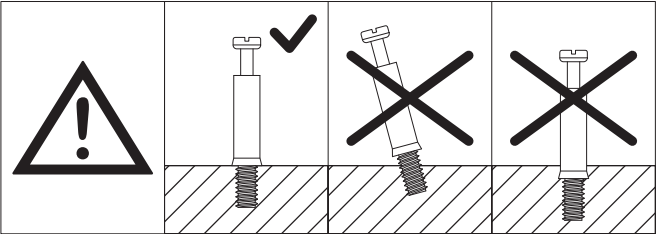
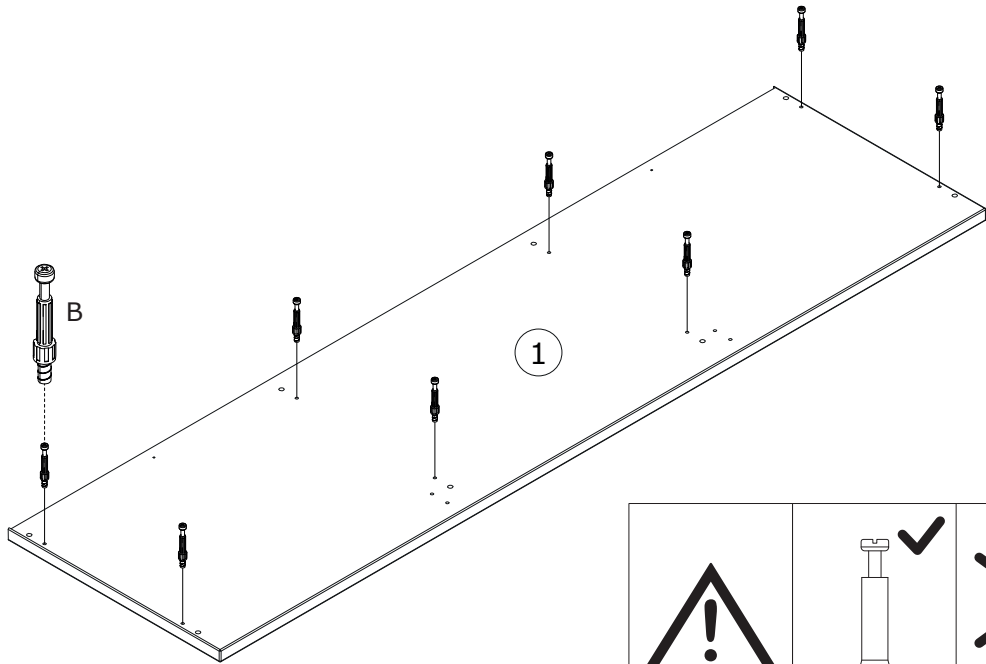
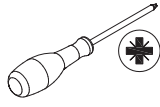

2

G x 4
Ø5x10mm

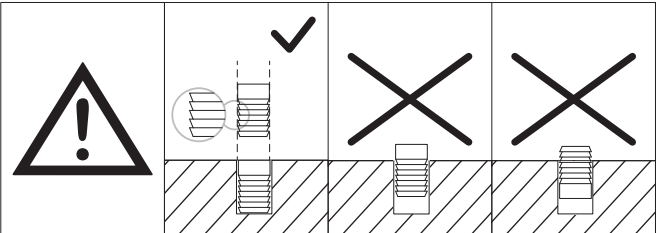
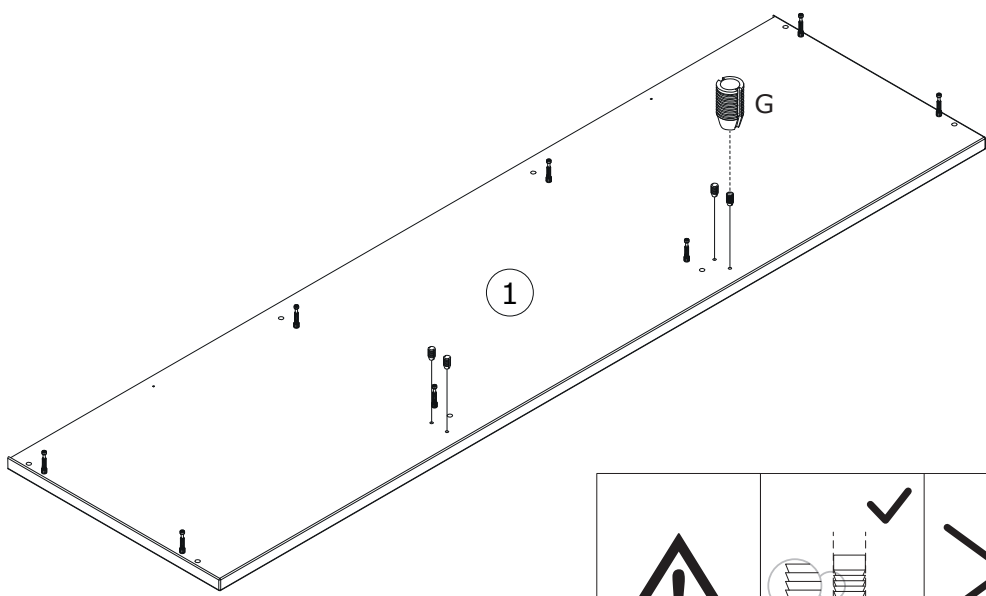
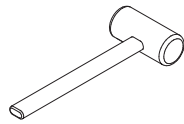

3

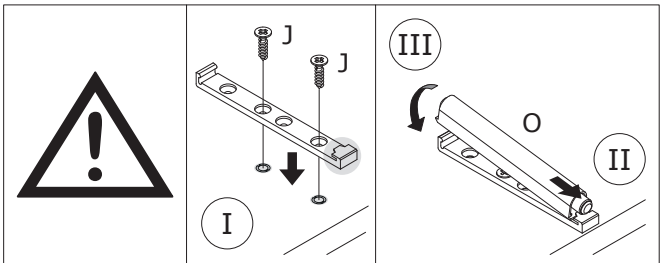
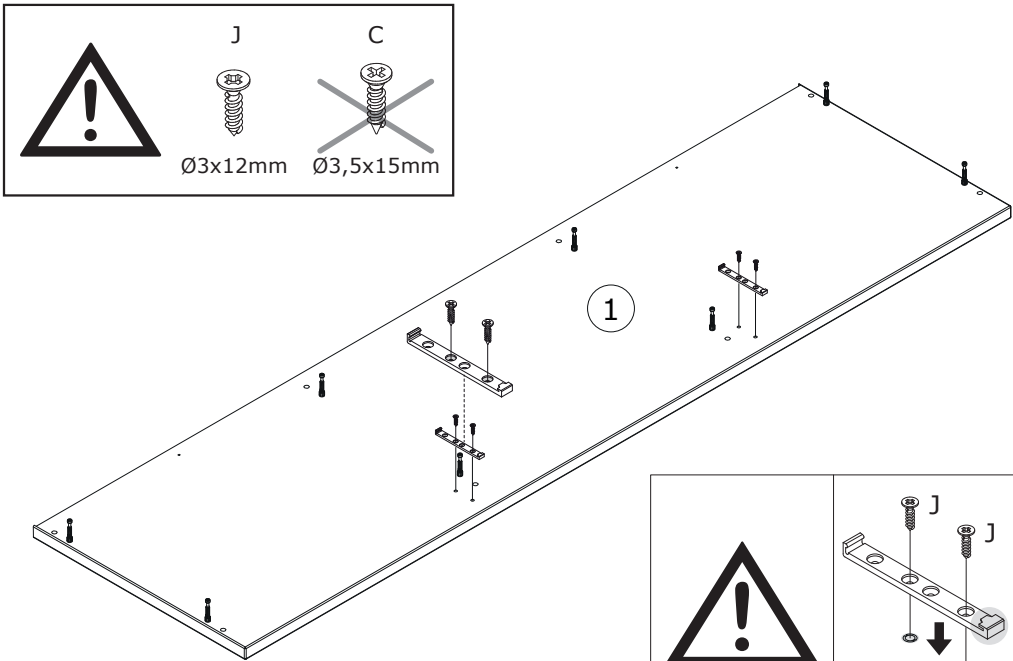
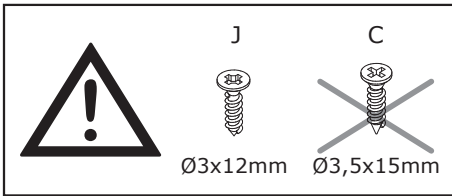
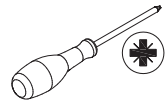
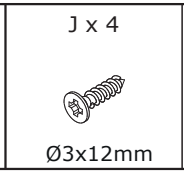
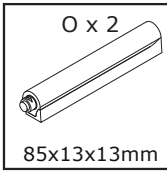

4

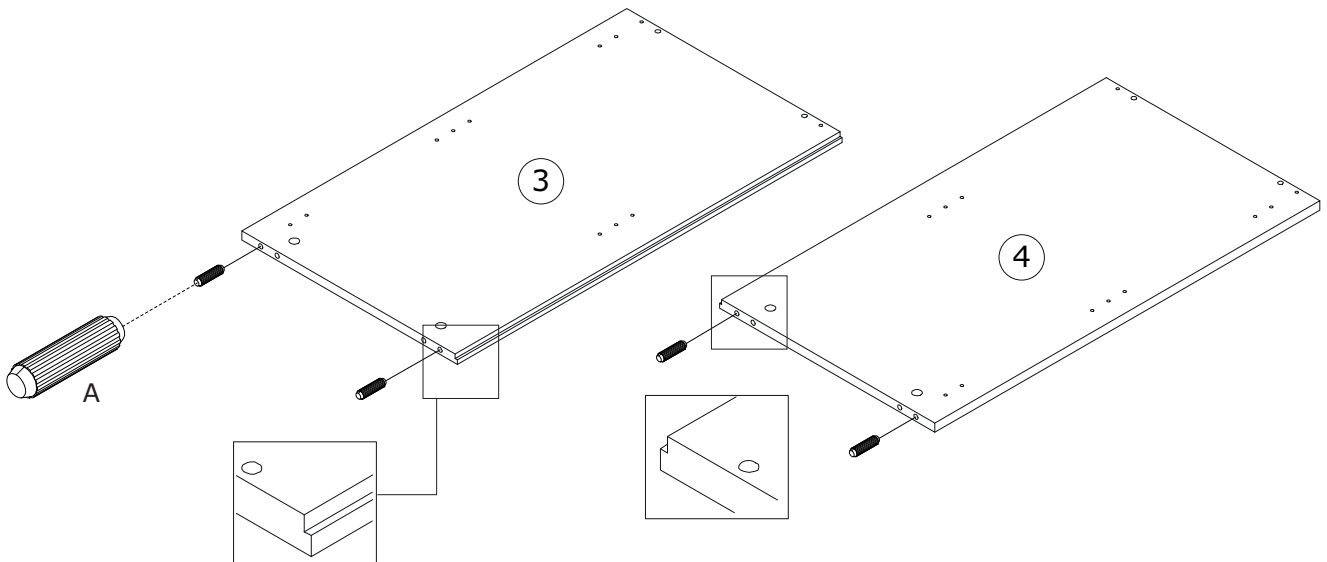
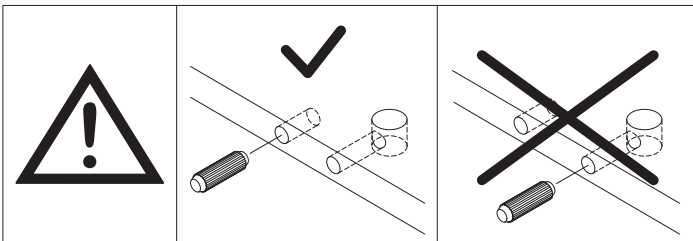
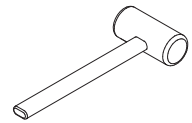
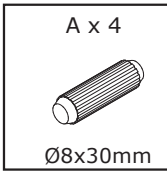

5

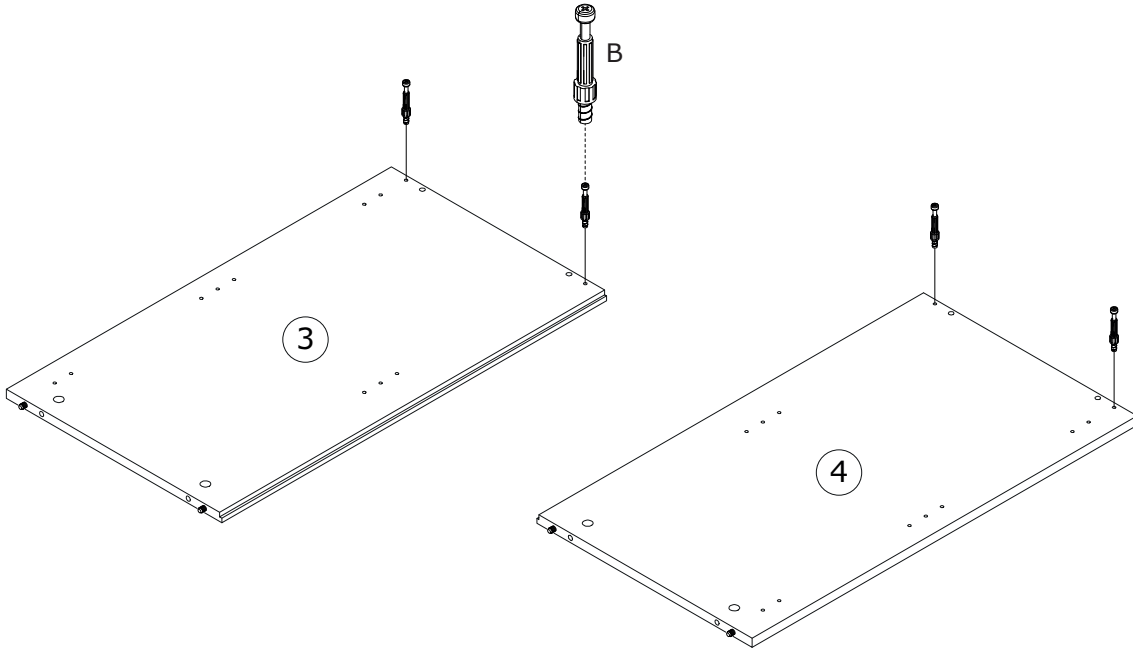
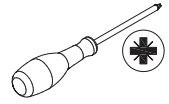
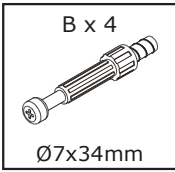

6

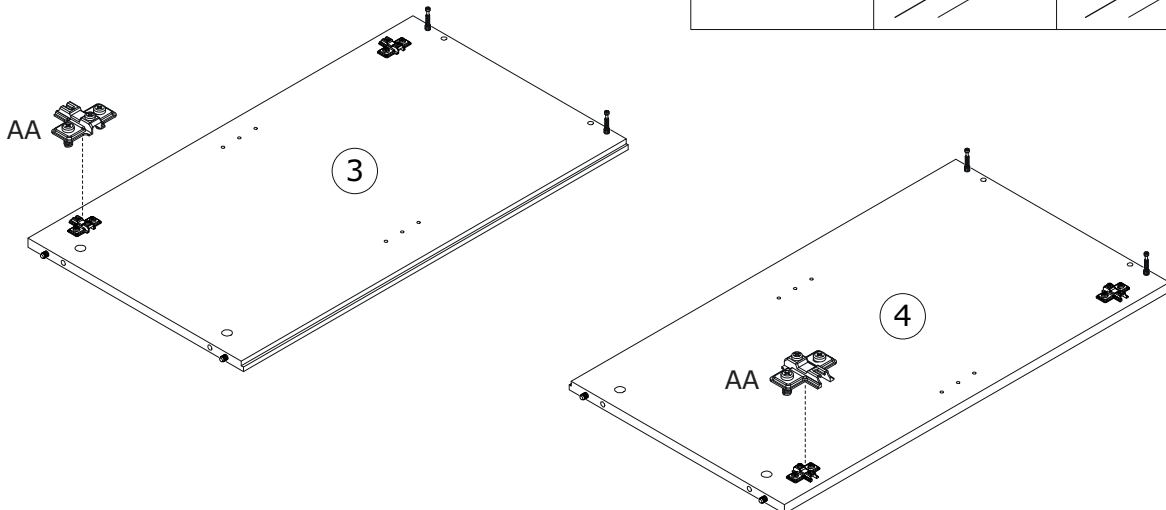
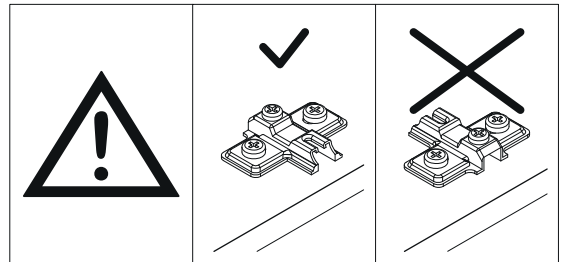
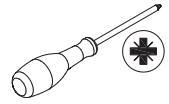
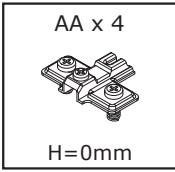

7

A x 4



Ø8x30mm

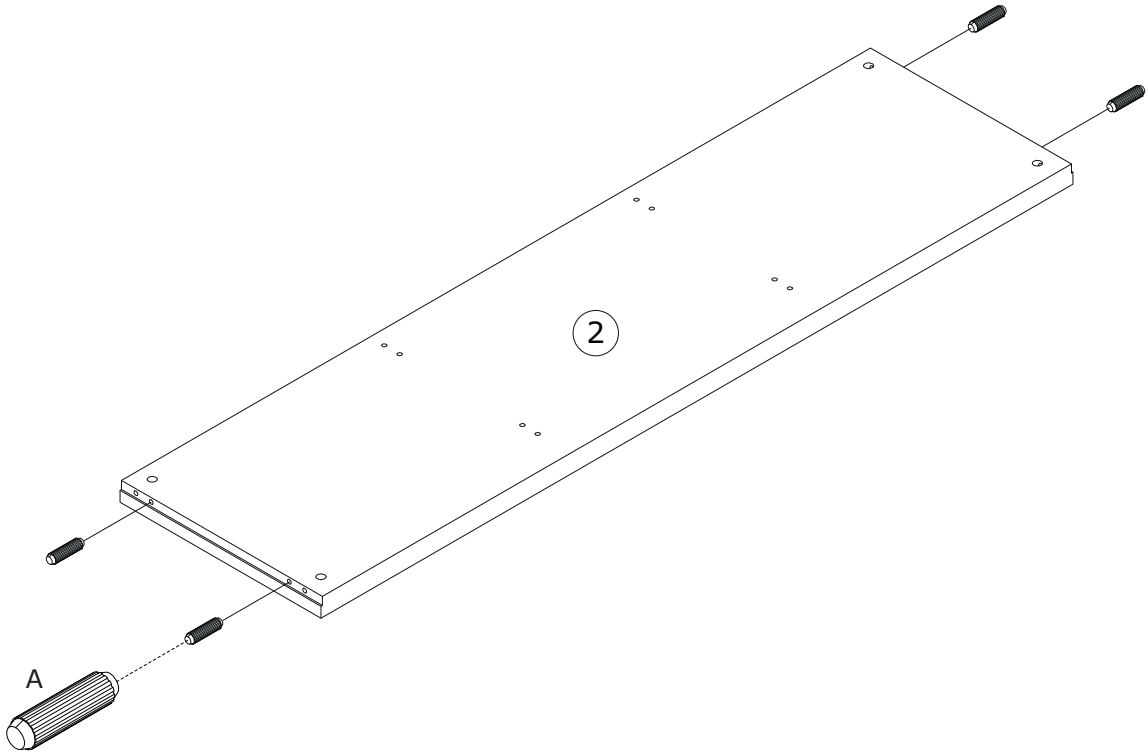
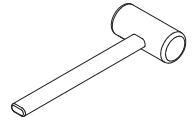

8

A x 8



Ø8x30mm

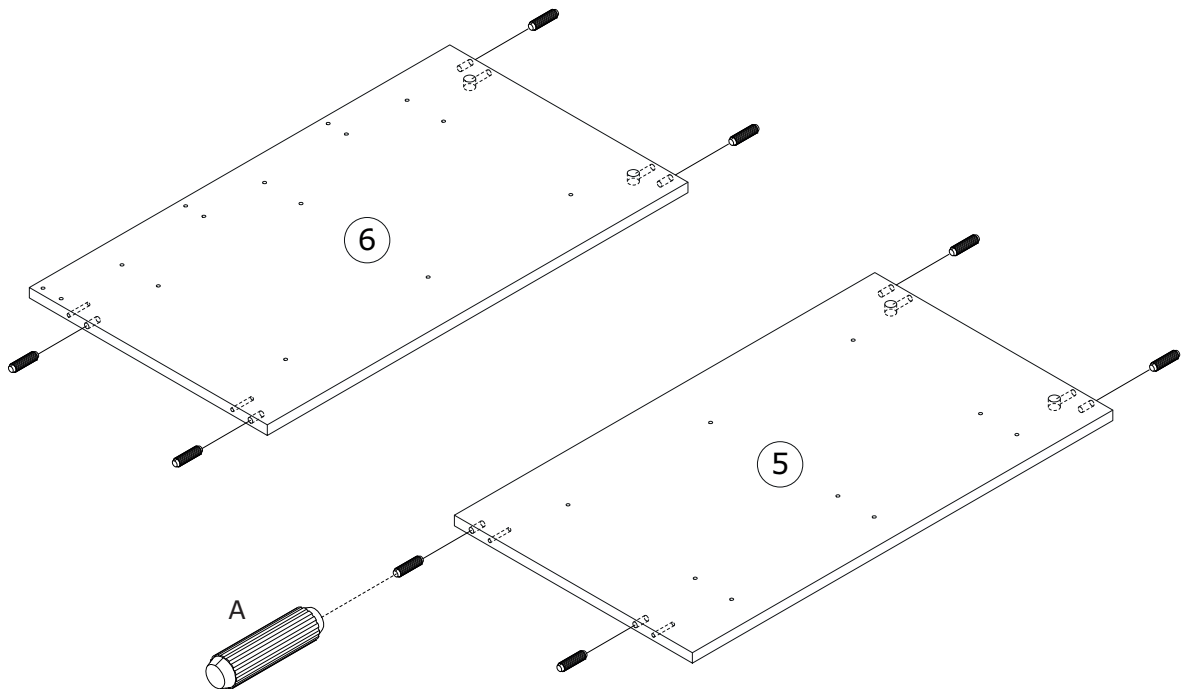
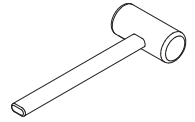

9

G x 24



Ø5x10mm

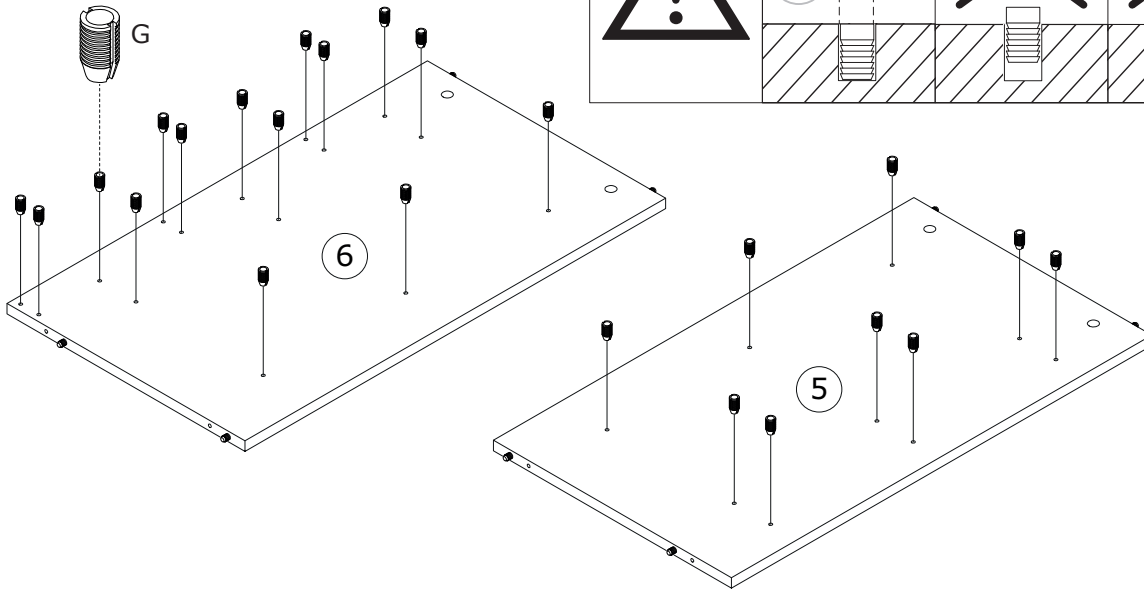
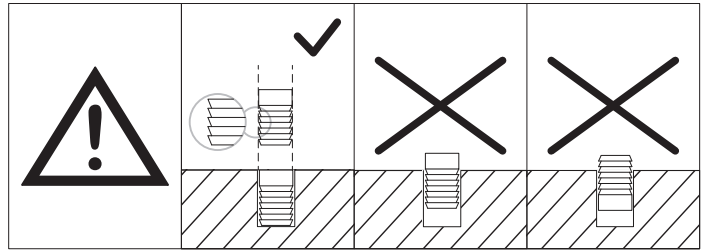
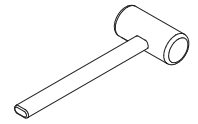

10

AD x 6





400x35x12,5mm



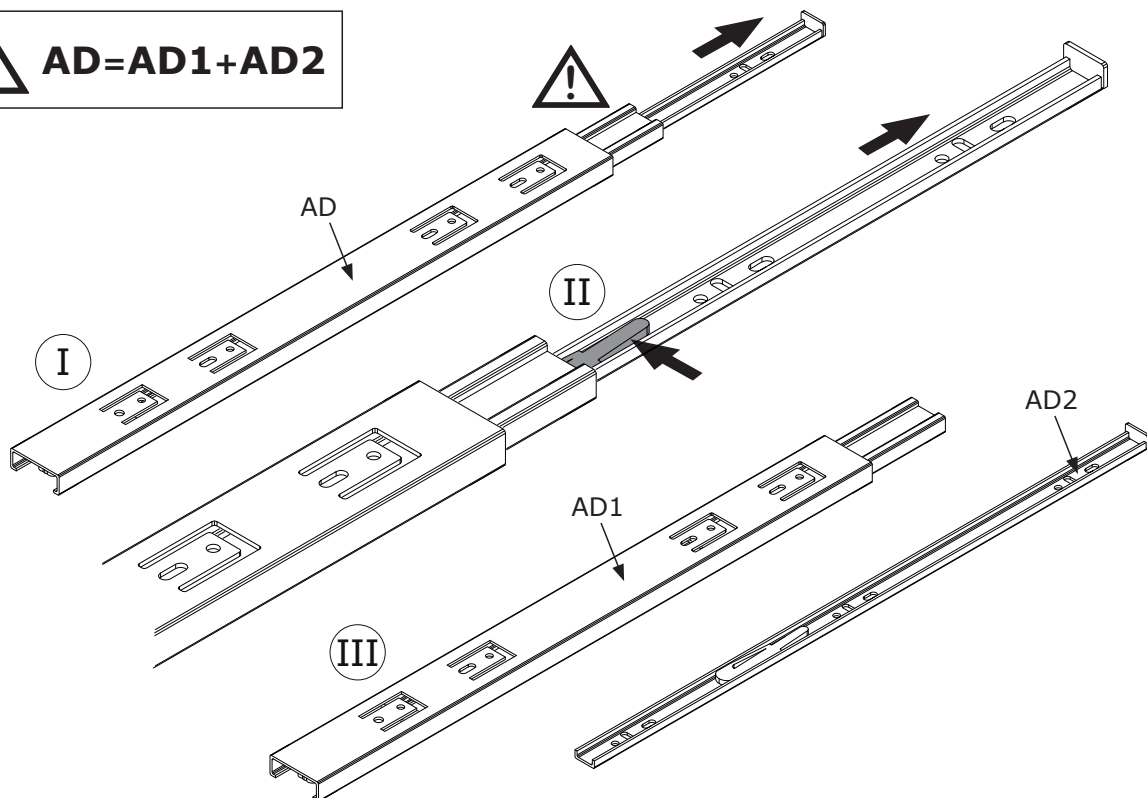



AD=AD1+AD2

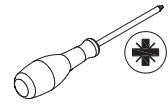

11

C x 9  Ø3,5x15mm	AD1 x 3  400x35x12,5mm
---	---



	C  Ø3,5x15mm	J  Ø3x12mm
---	---	---

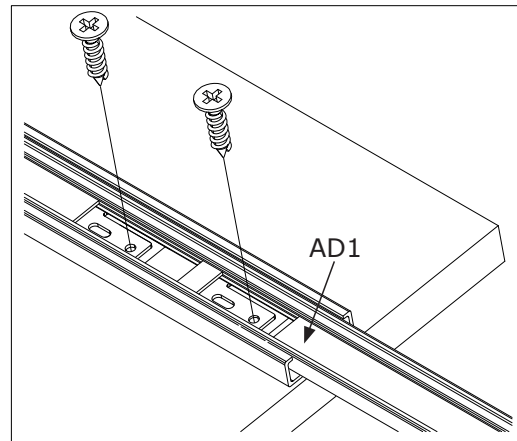
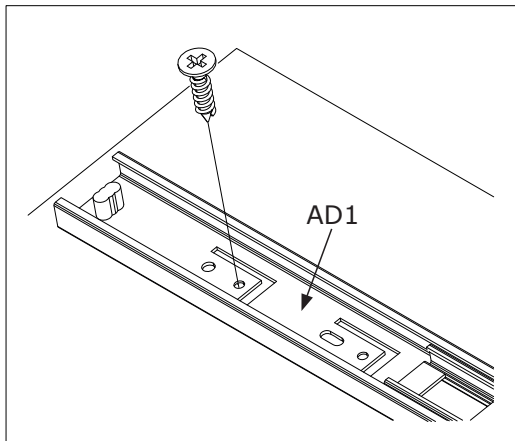
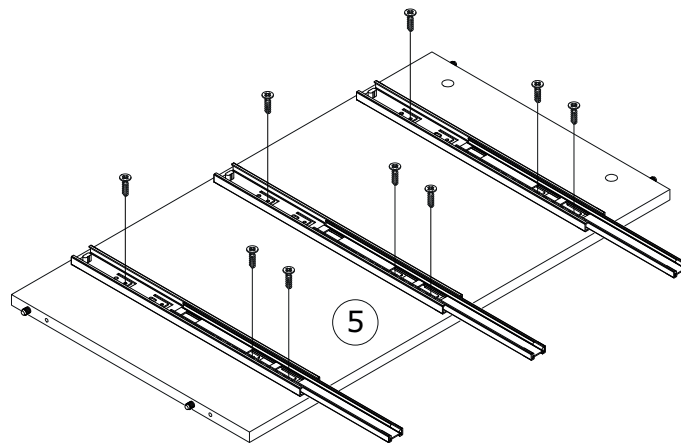
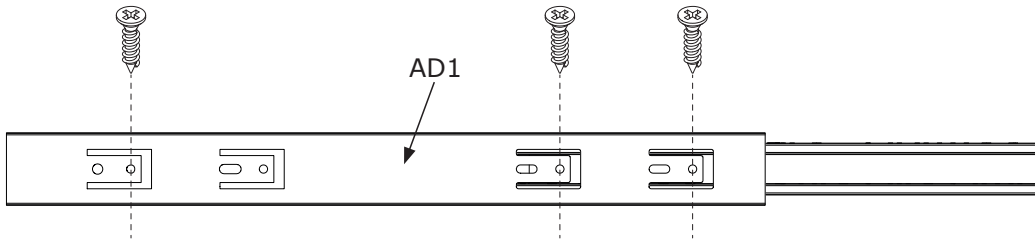

12

C x 9



Ø3,5x15mm

AD1 x 3

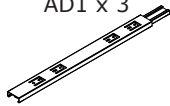

400x35x12,5mm

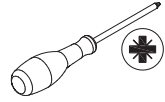

C



Ø3,5x15mm

J

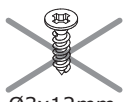

Ø3x12mm

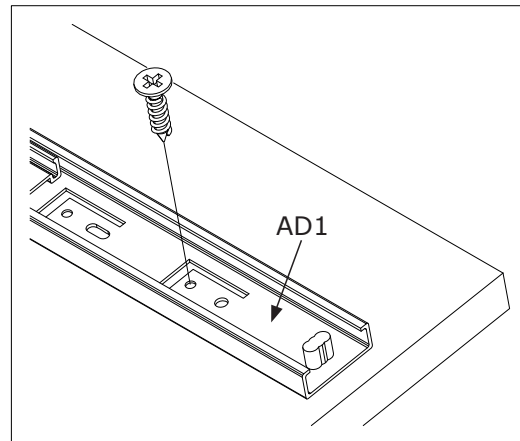
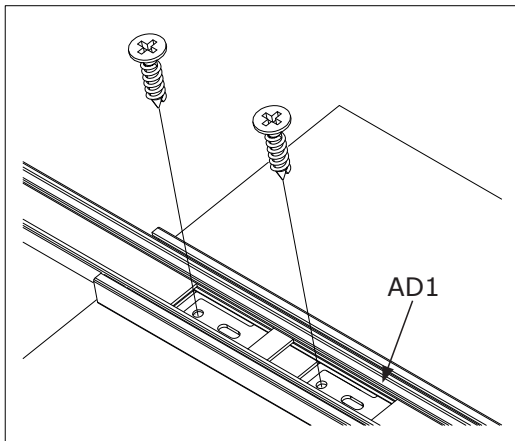
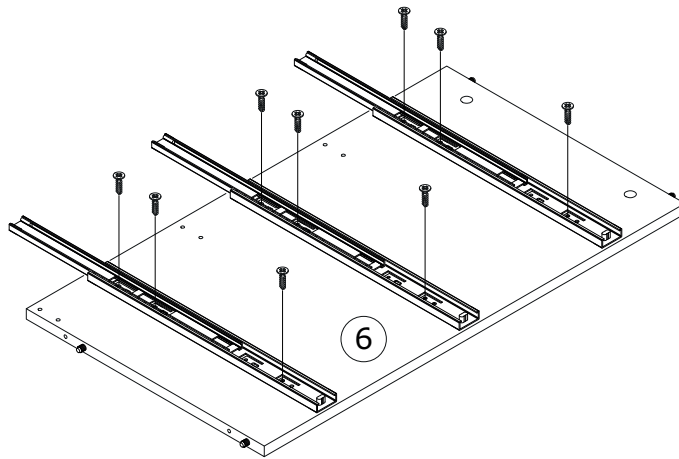
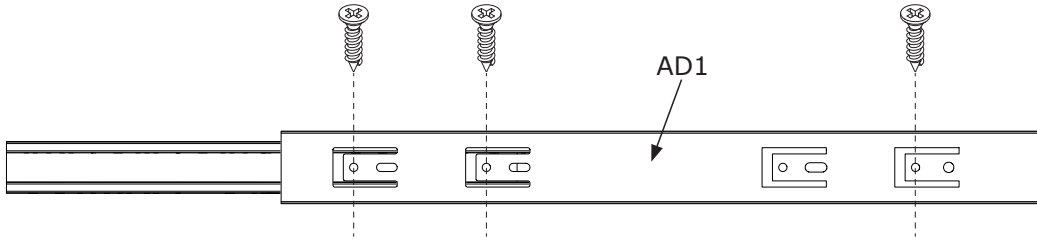

13

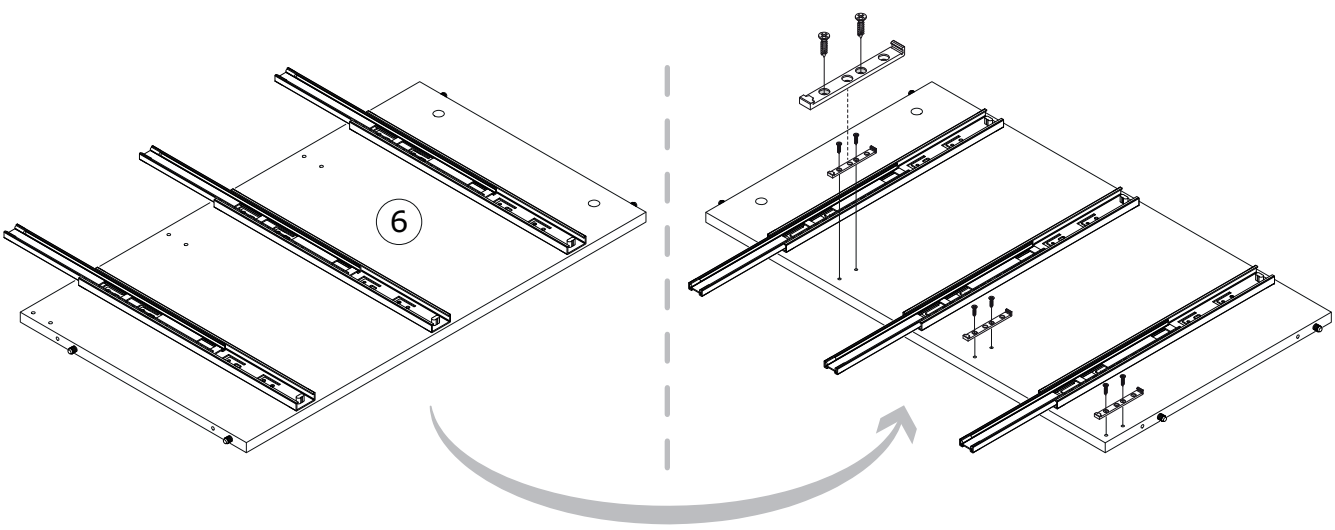
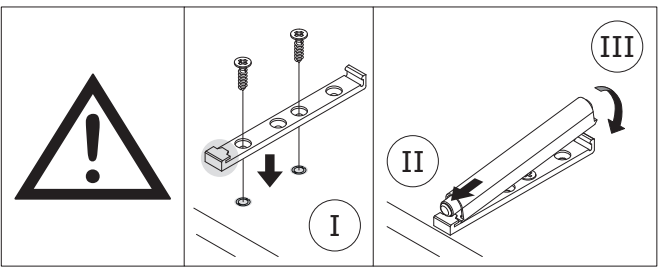
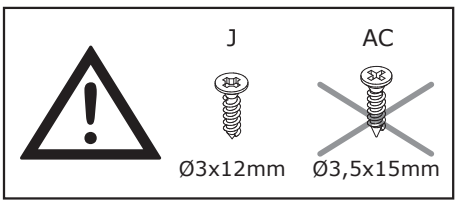
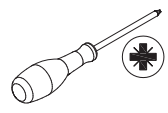
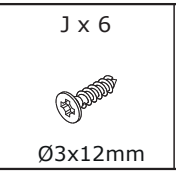
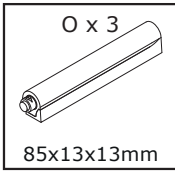

14

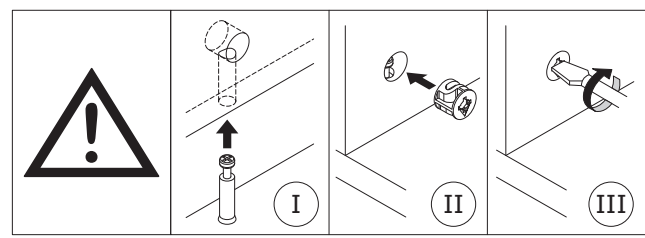
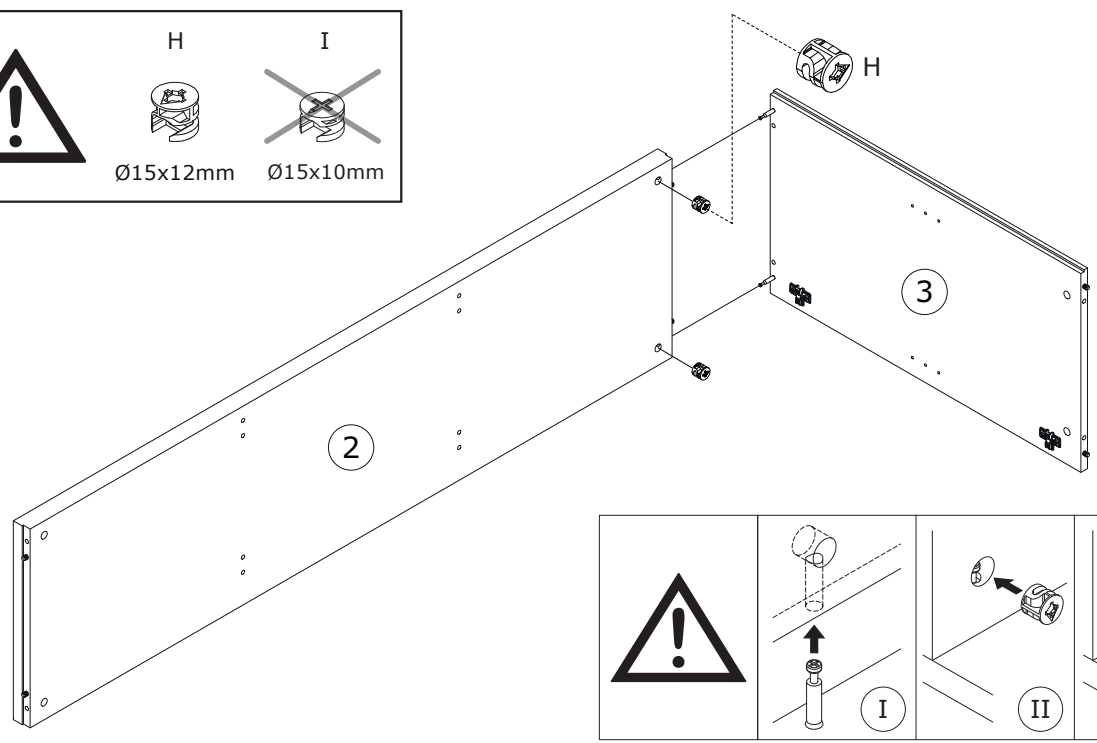
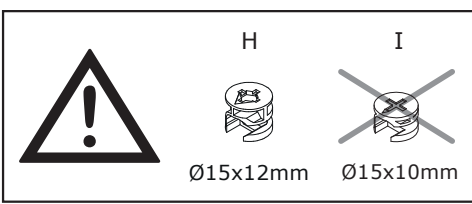
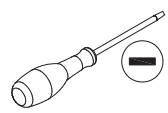
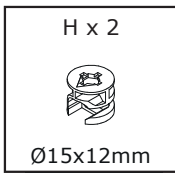

15

H x 2



Ø15x12mm

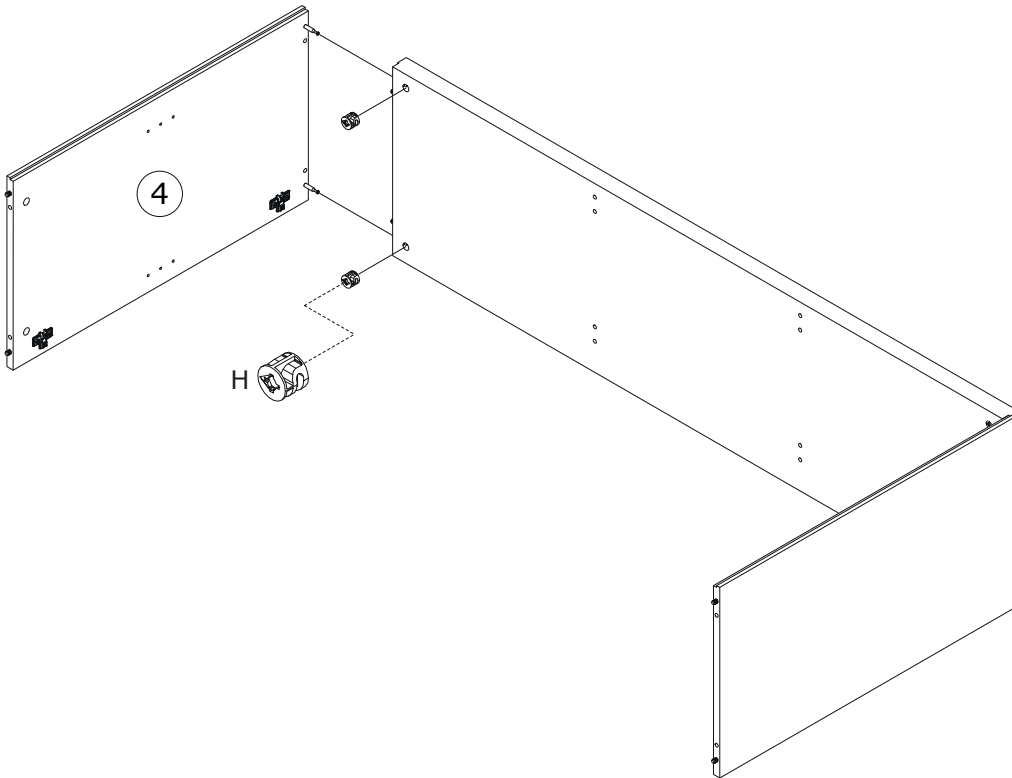
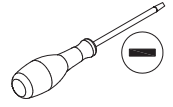

16

M x 4



Ø6,3x70mm

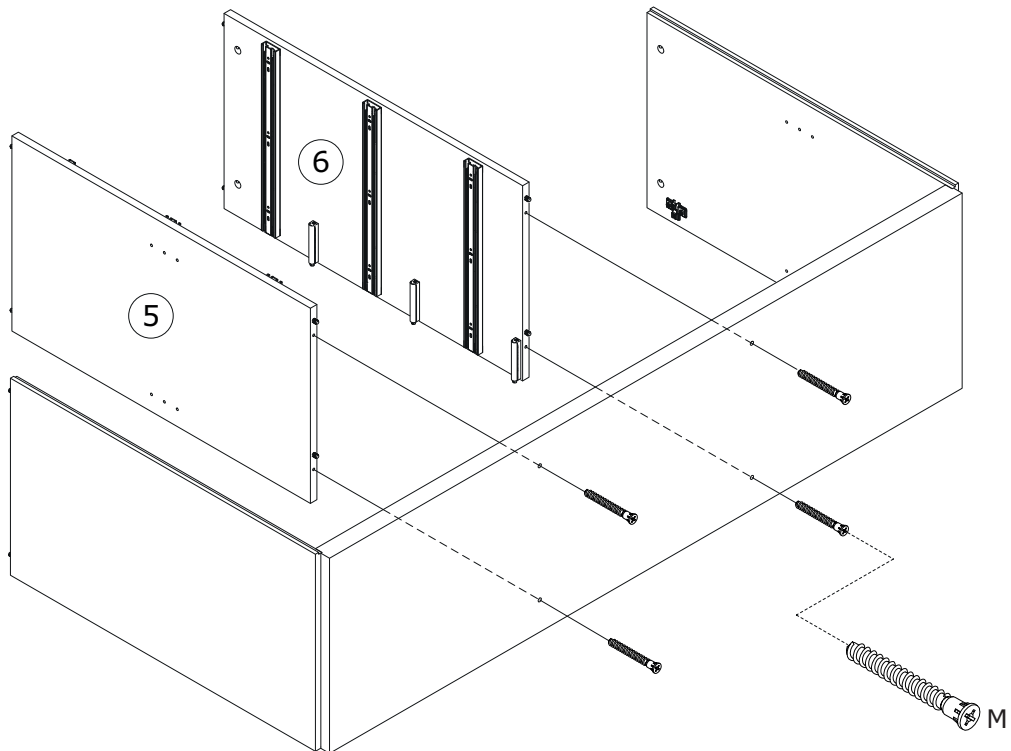
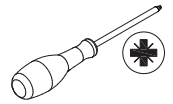

17

H x 8



Ø15x12mm

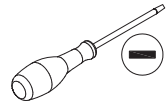

H



Ø15x12mm

I



Ø15x10mm

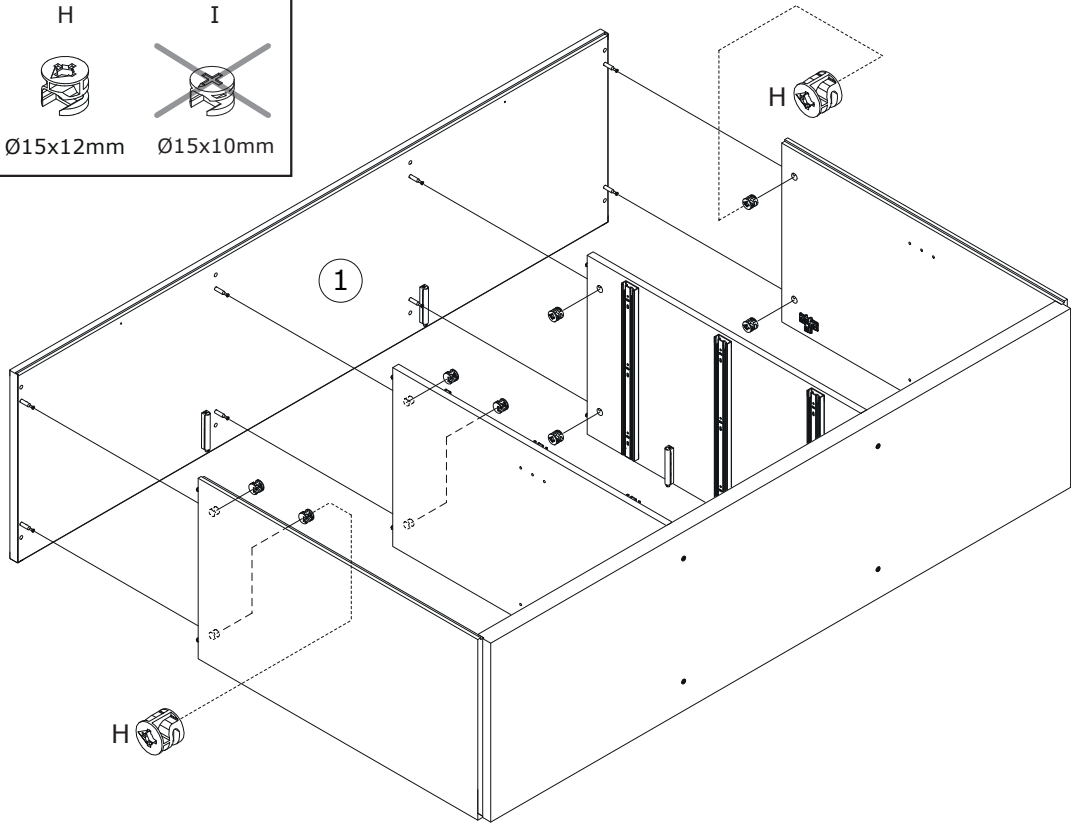

18

D x 6



Ø30x3,5mm

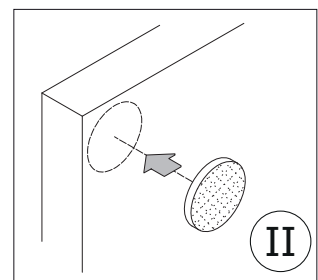
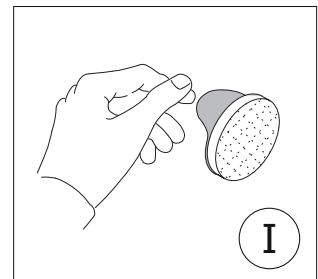
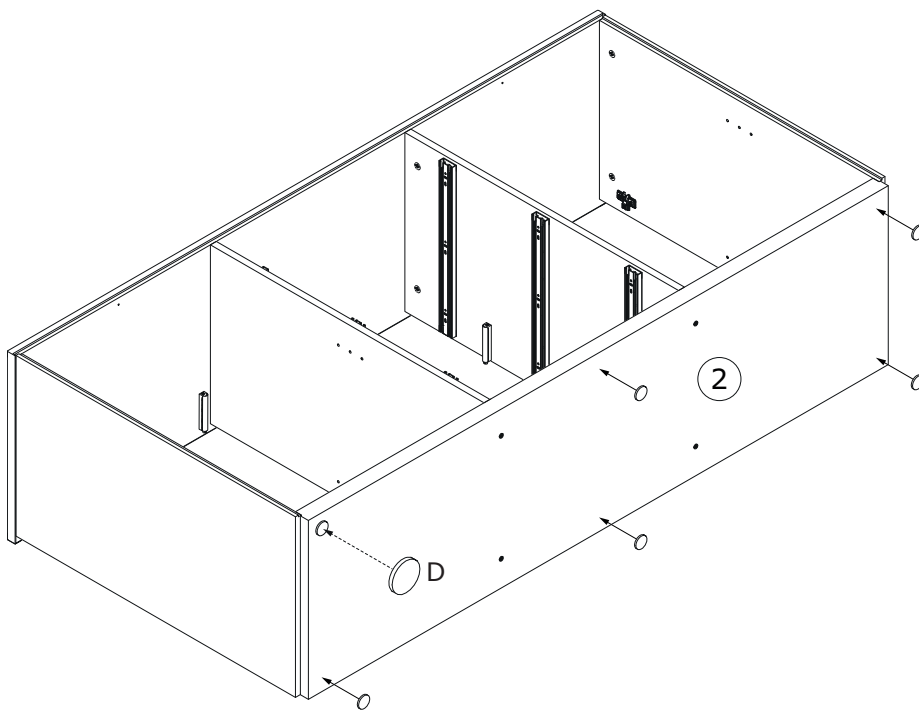

19

E x 50



Ø1,2x25mm

Q x 1



40x20x10/16mm

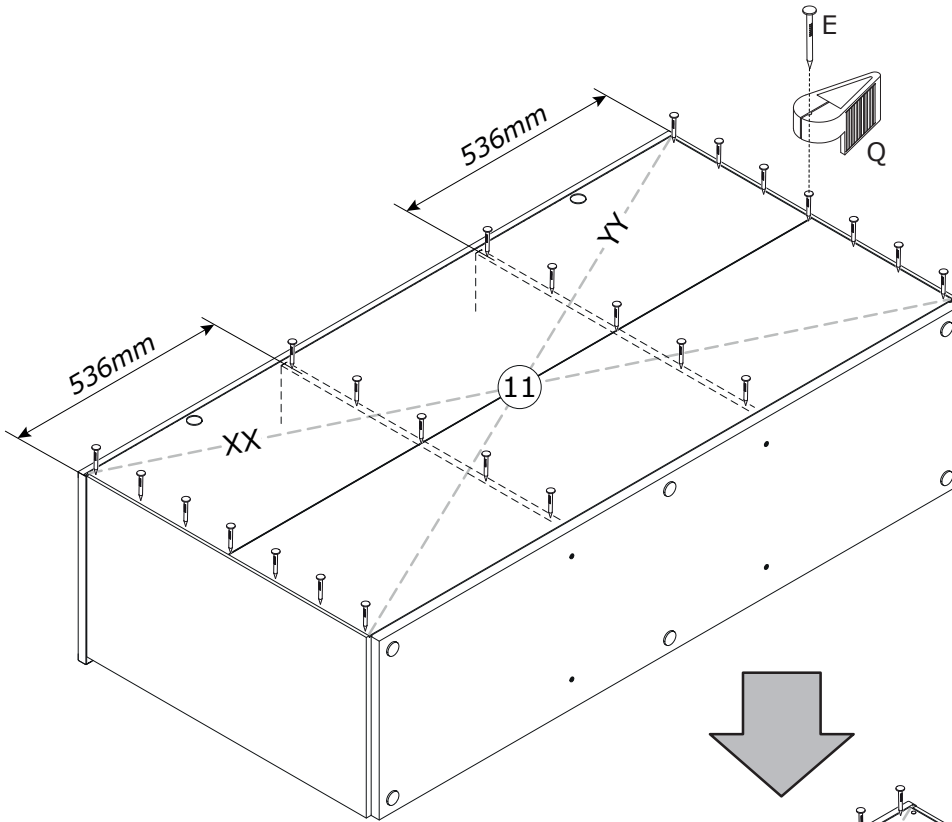
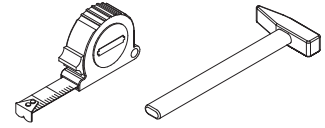

XX = YY = 90°

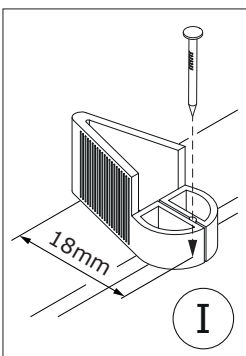
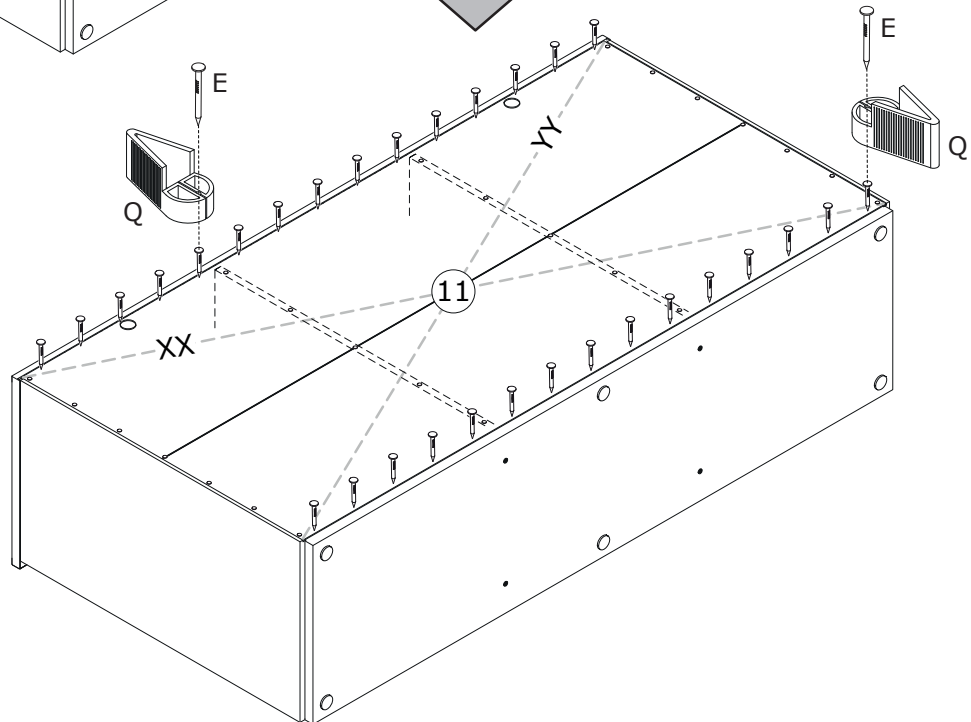
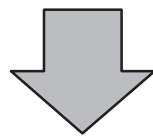

I

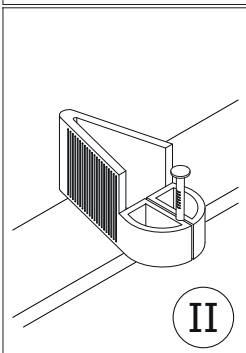

II

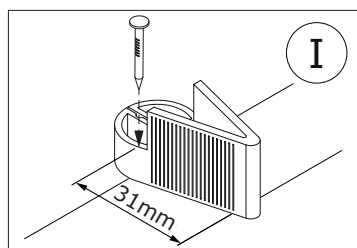

I

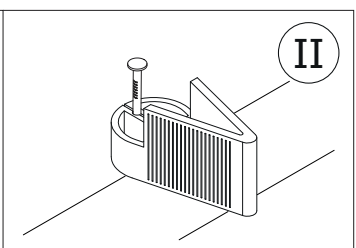

II

20

F x 8



12x14x14mm

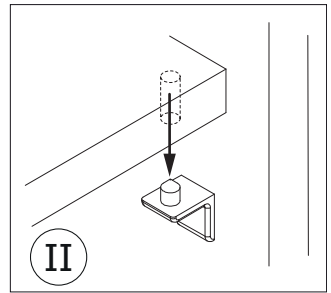
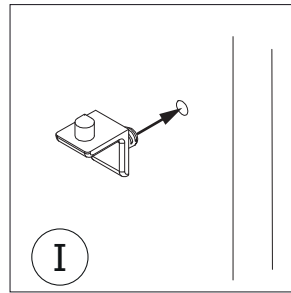
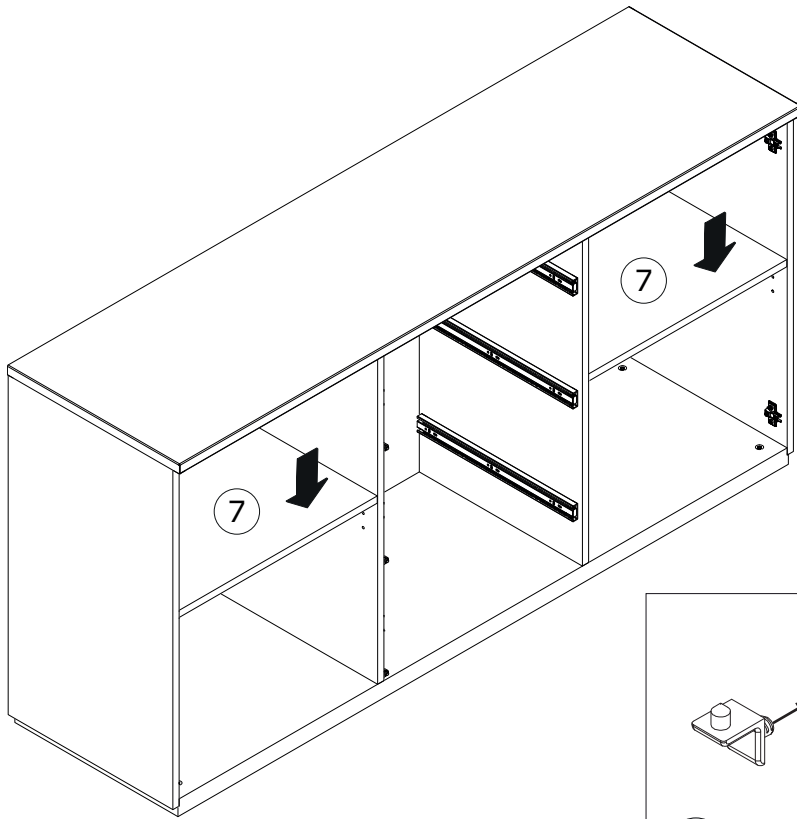

21

R x 2

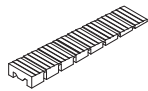

100x20x8/1mm

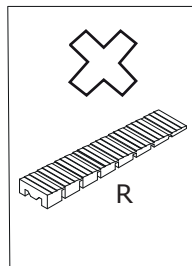
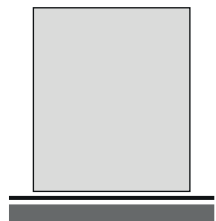
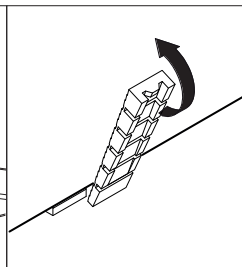
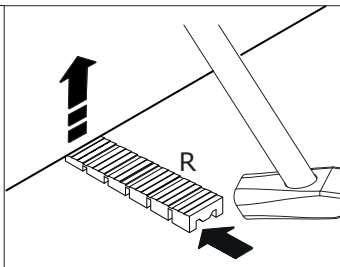
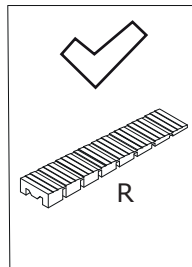
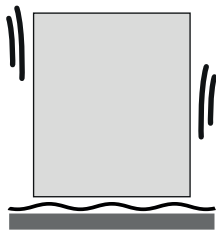
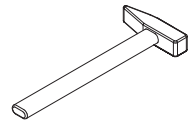

22

<p>S x 2 77x32x15mm</p> 	<p>T x 4 Ø4x15mm</p> 	<p>N x 4 Ø16x1mm</p> 	
---	--	--	---

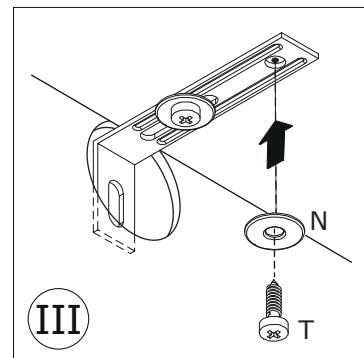
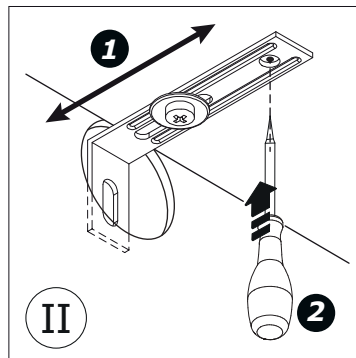
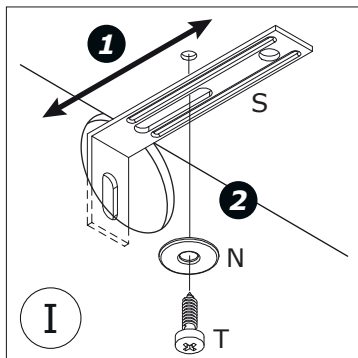
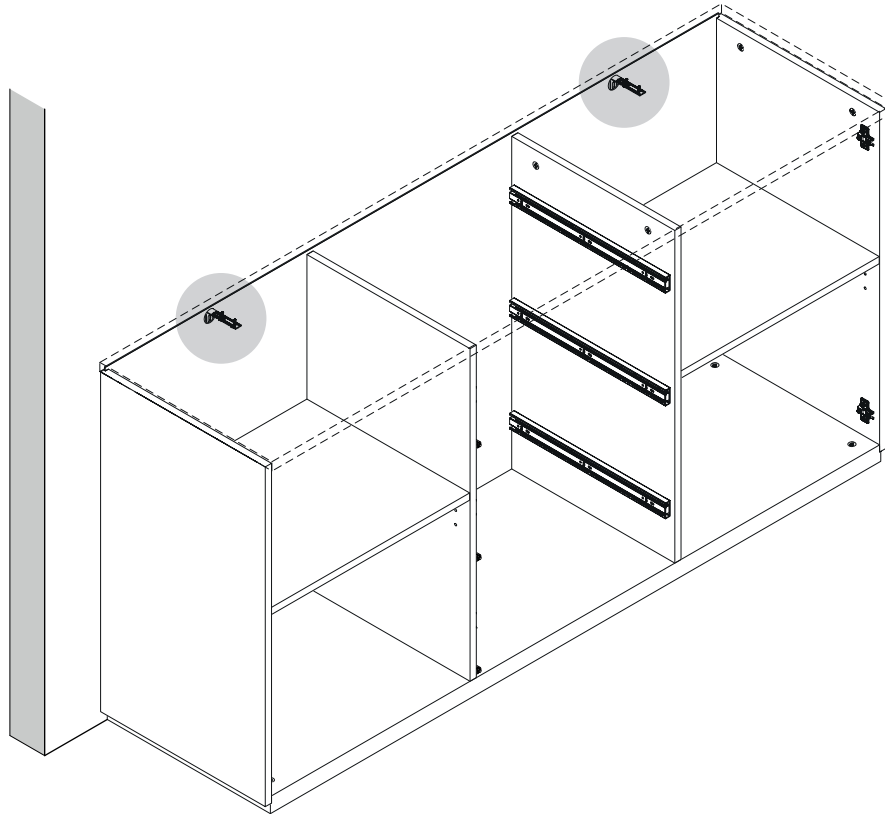

23

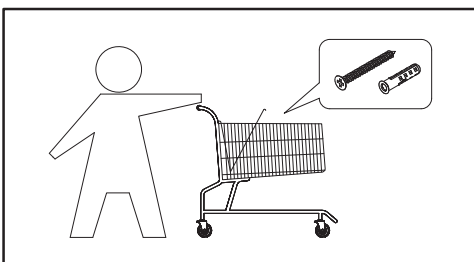
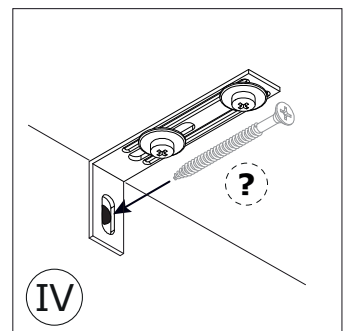
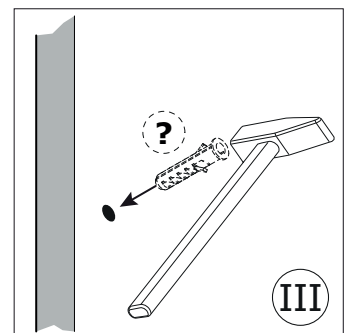
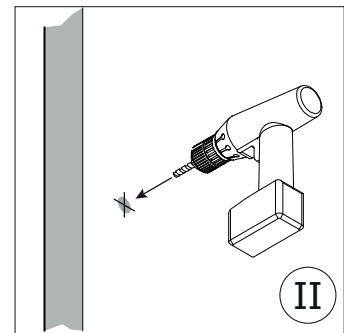
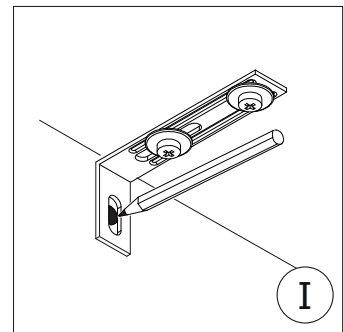
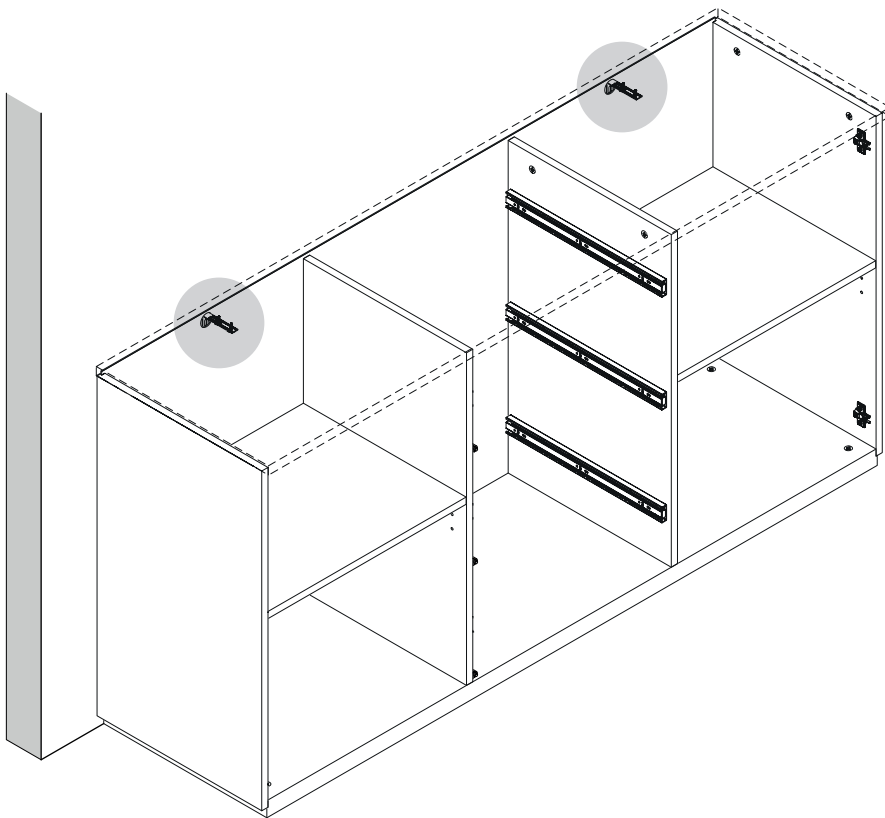
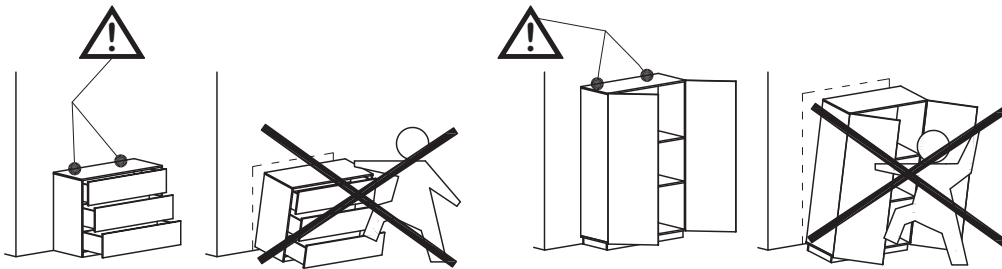
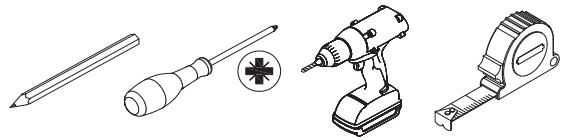

24

<p>B x 12</p>  <p>Ø7x34mm</p>	<p>N x 3</p>  <p>Ø16x1mm</p>	<p>J x 3</p>  <p>Ø3x12mm</p>	
--	---	---	---

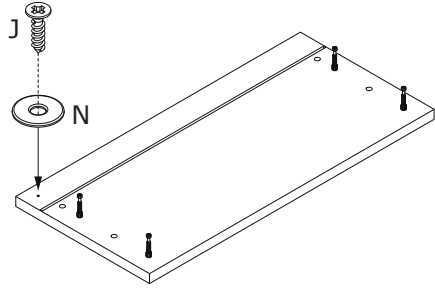
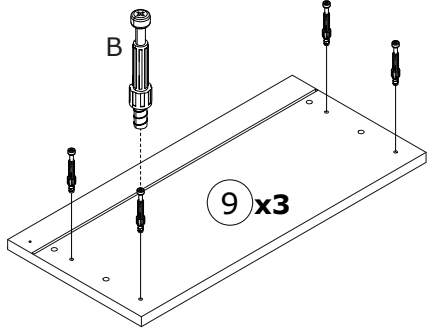
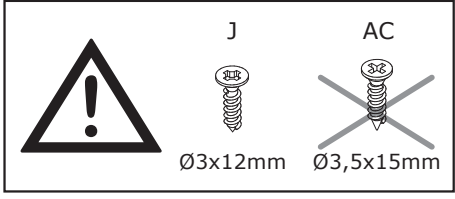
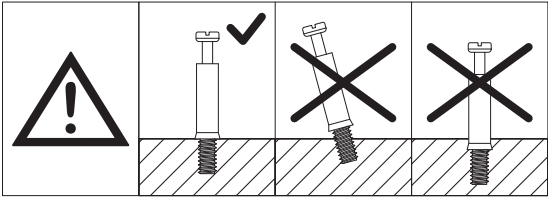

25

<p>I x 12</p>  <p>Ø15x10mm</p>	
---	--

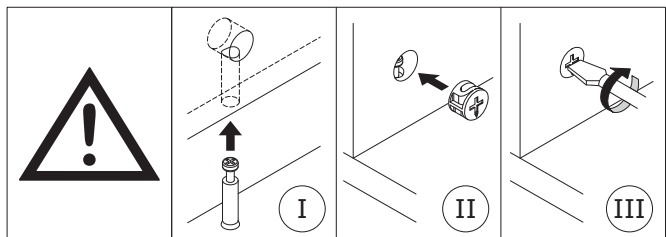
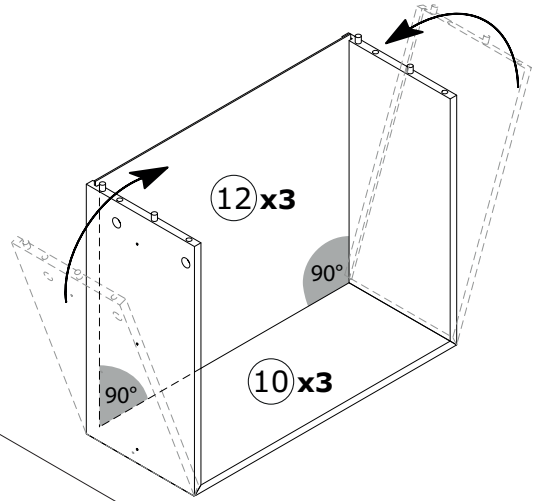
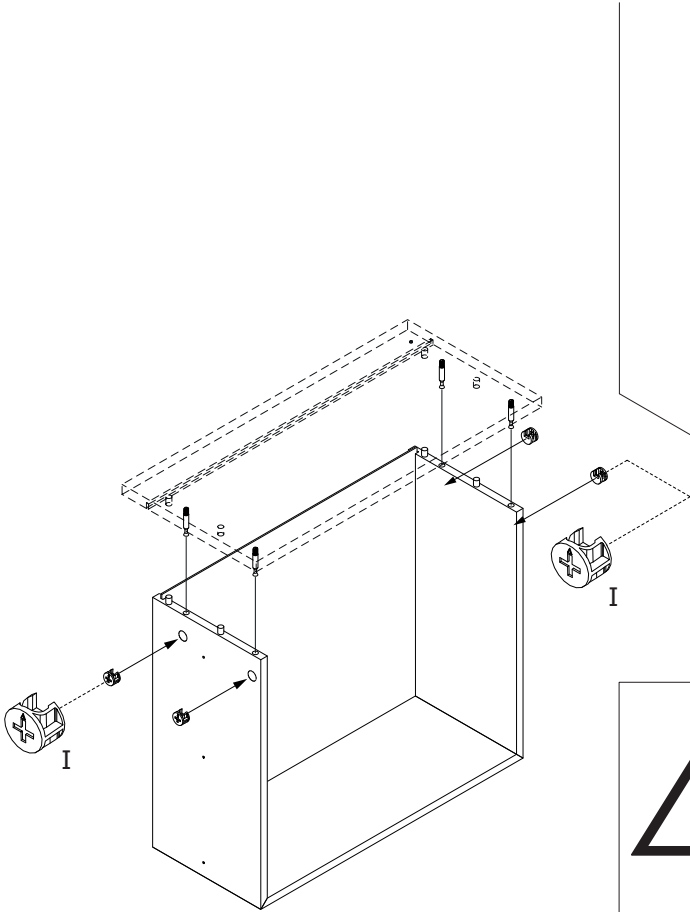

26

J x 18
Ø3x12mm

AD2 x 6
400x14x9,5mm

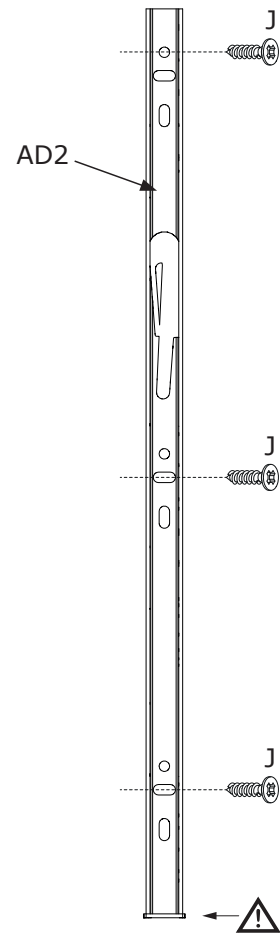
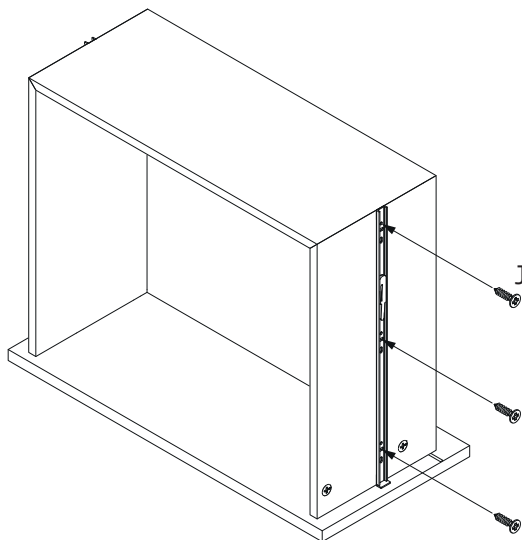
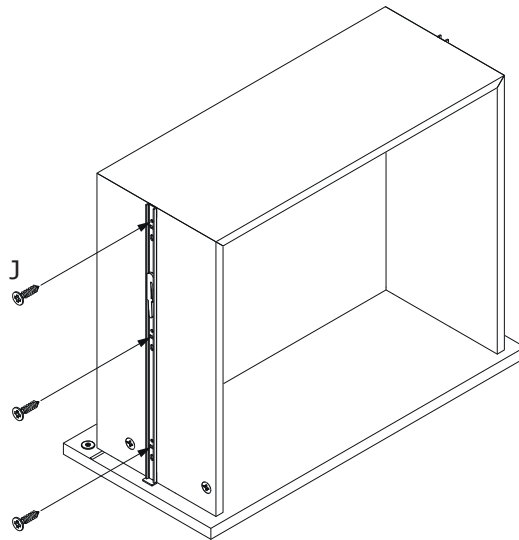
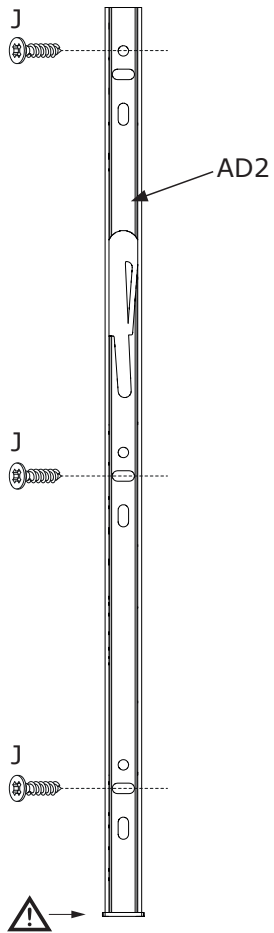
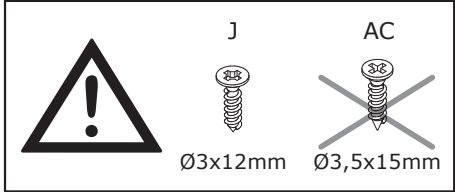
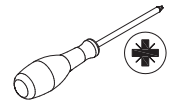

27

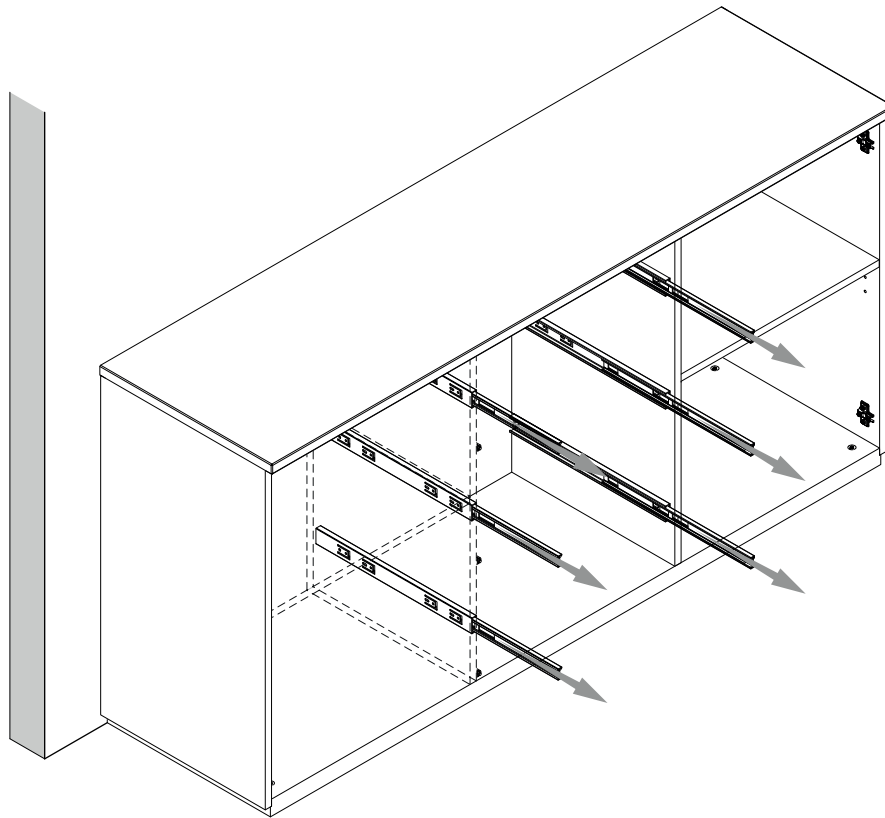

28

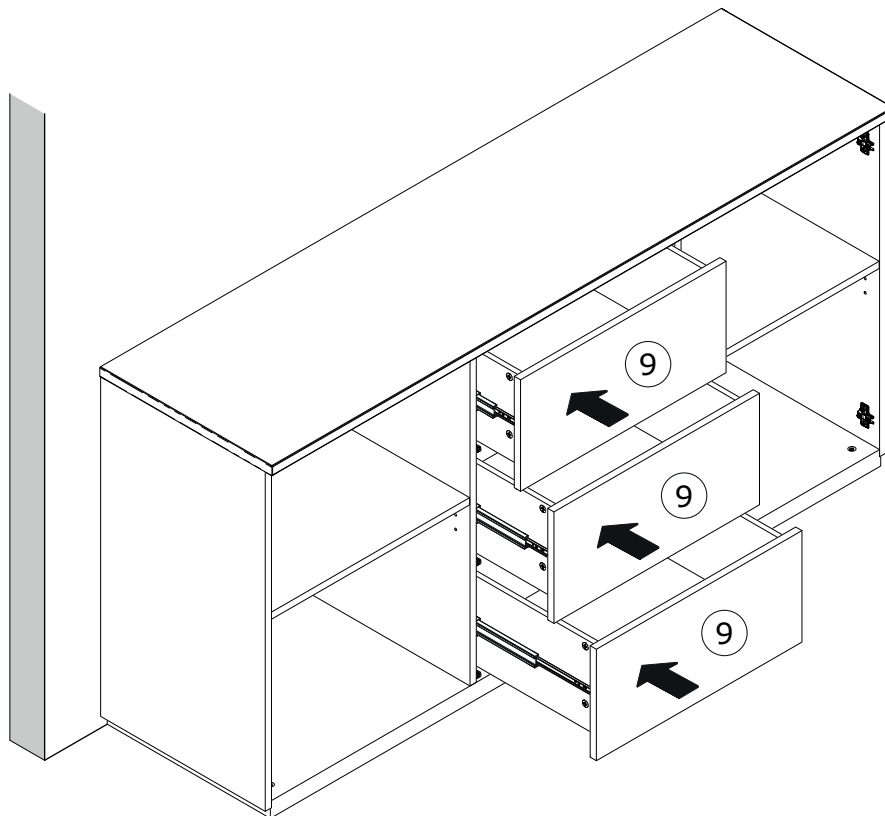

29

J x 6



Ø3x12mm

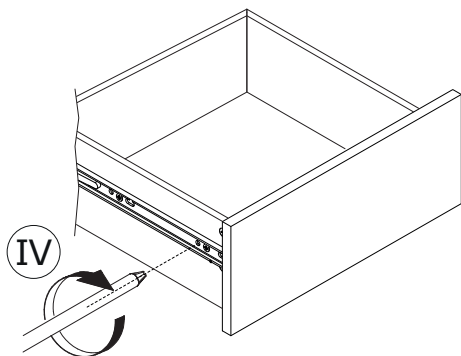
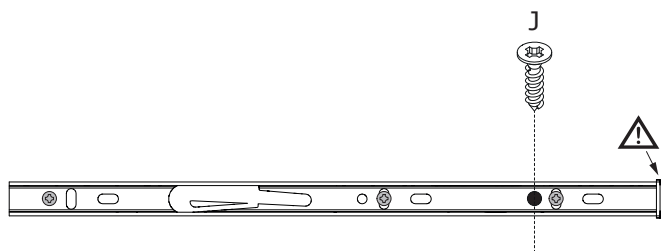
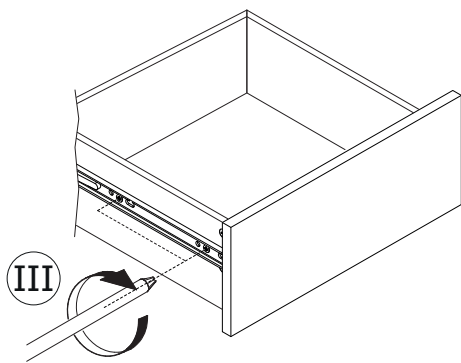
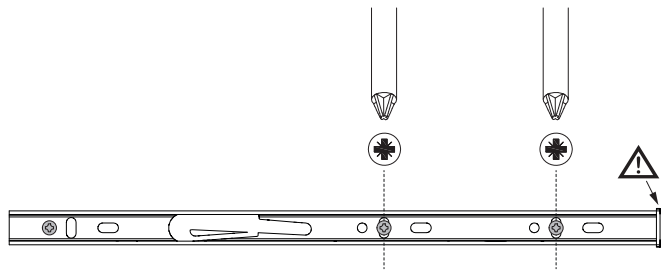
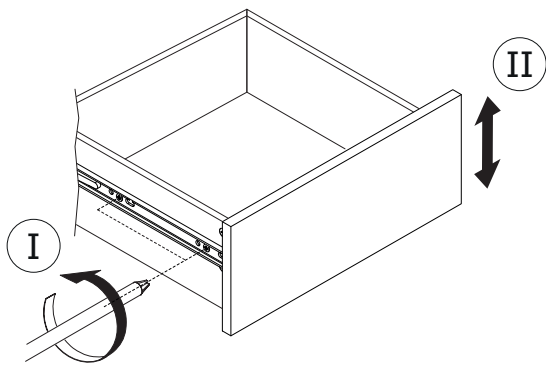
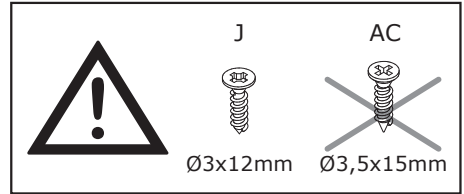
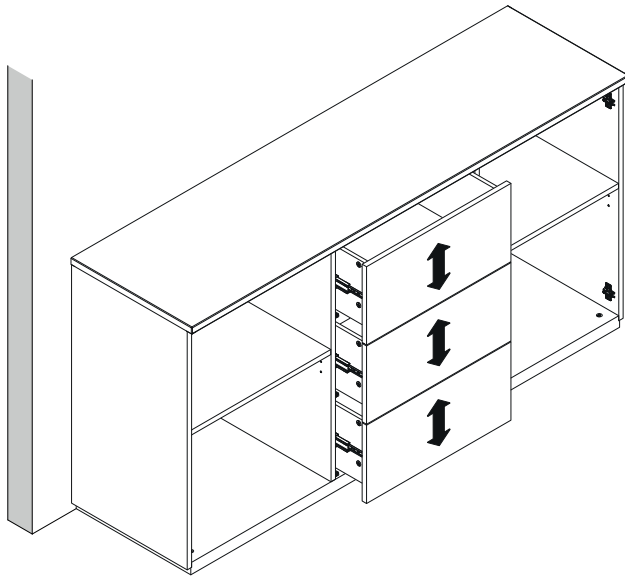
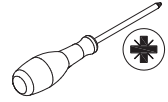

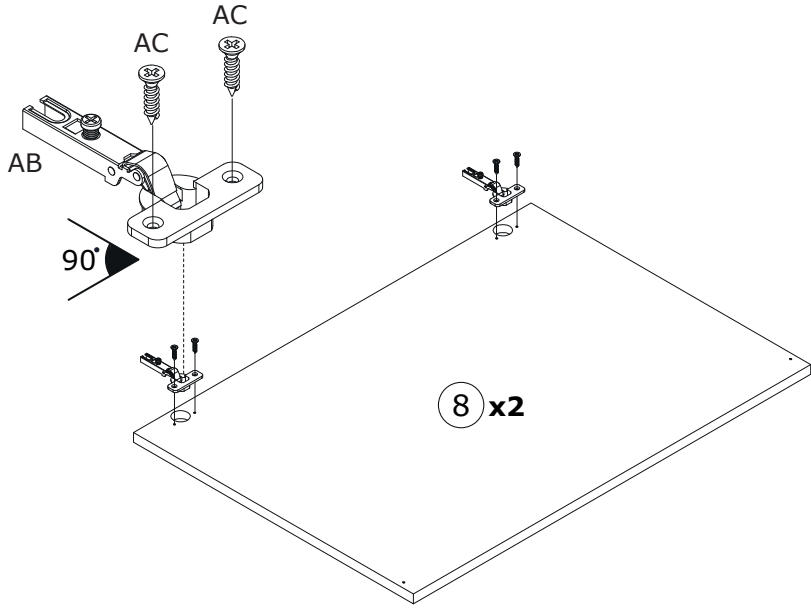

30

AB x 4  Ø26mm,FK0	AC x 8  Ø3,5x15mm	
--	--	---



31

N x 2  Ø16x1mm	J x 2  Ø3x12mm	
---	---	---

	J  Ø3x12mm	AC  Ø3,5x15mm
---	---	---

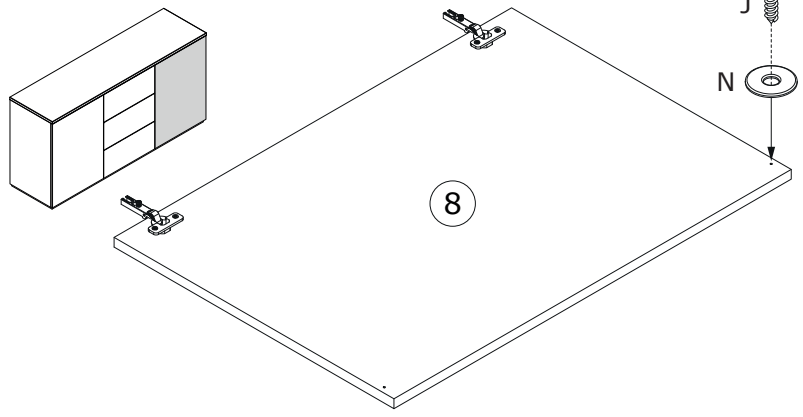
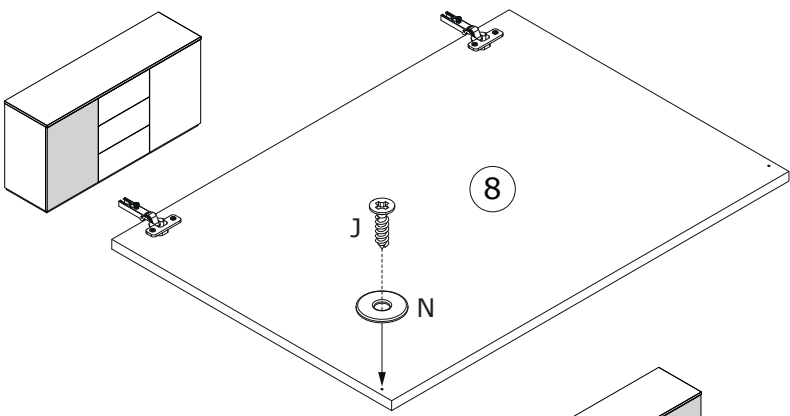

32

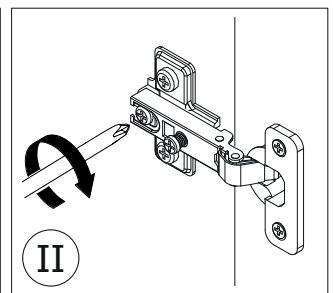
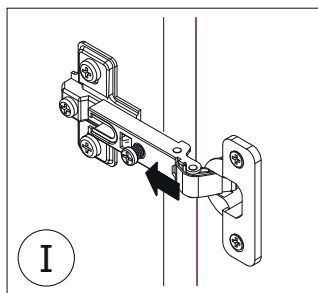
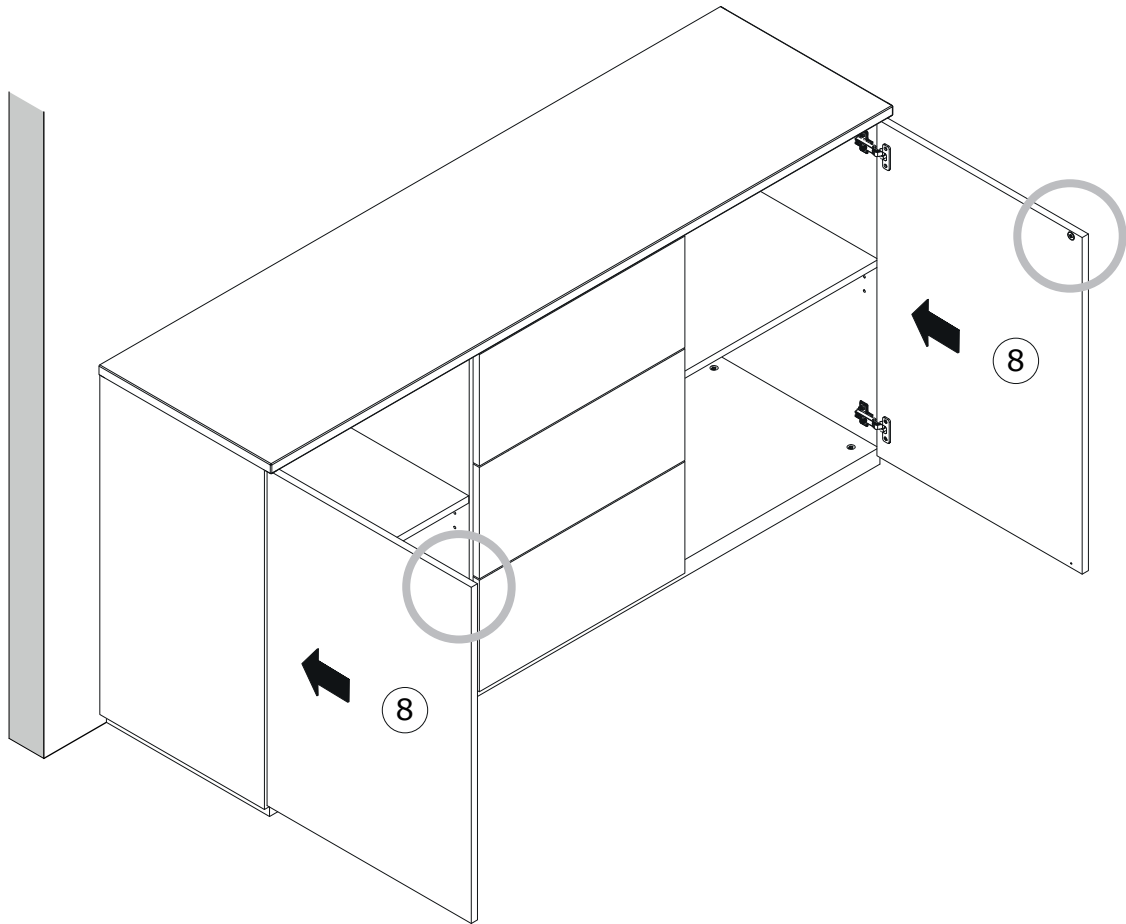
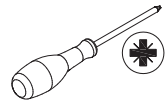

33

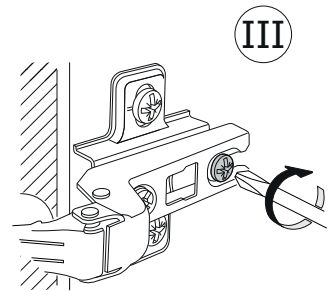
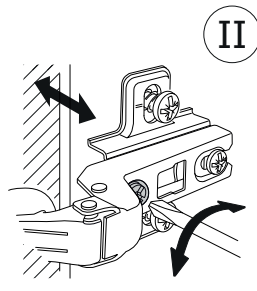
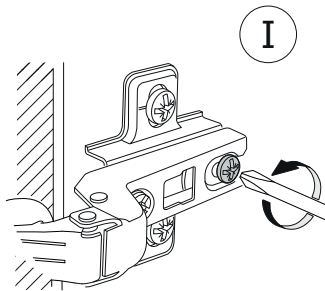
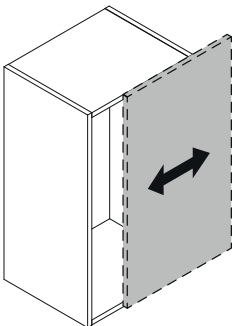
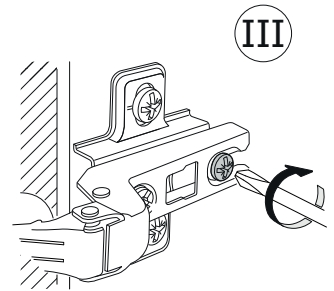
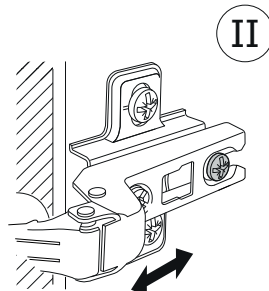
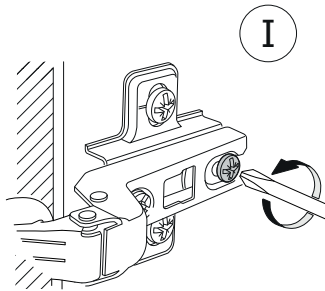
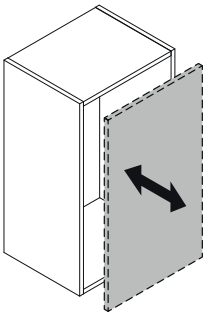
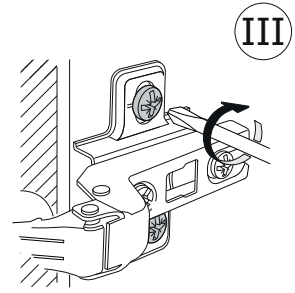
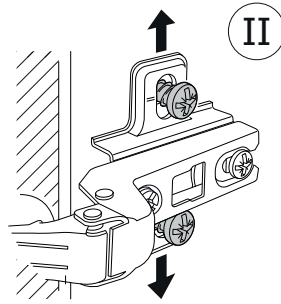
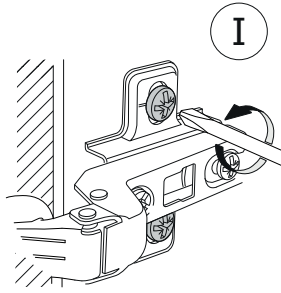
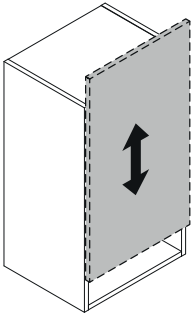

34

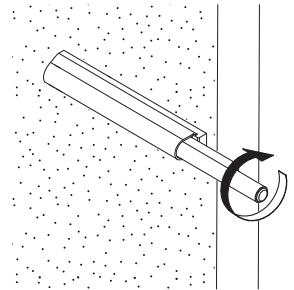
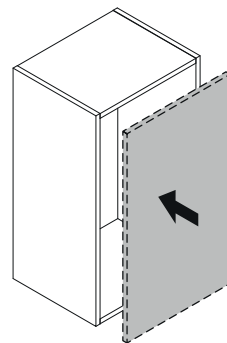
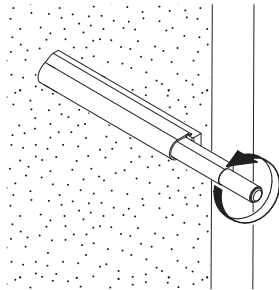
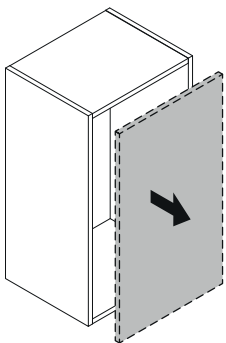

35

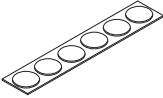
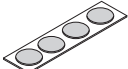
K x 16  Ø20mm	L x 4  Ø20mm	
--	---	--

