

NORDBY

128355/ 720-236-1010

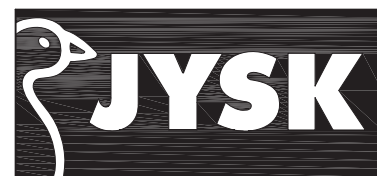

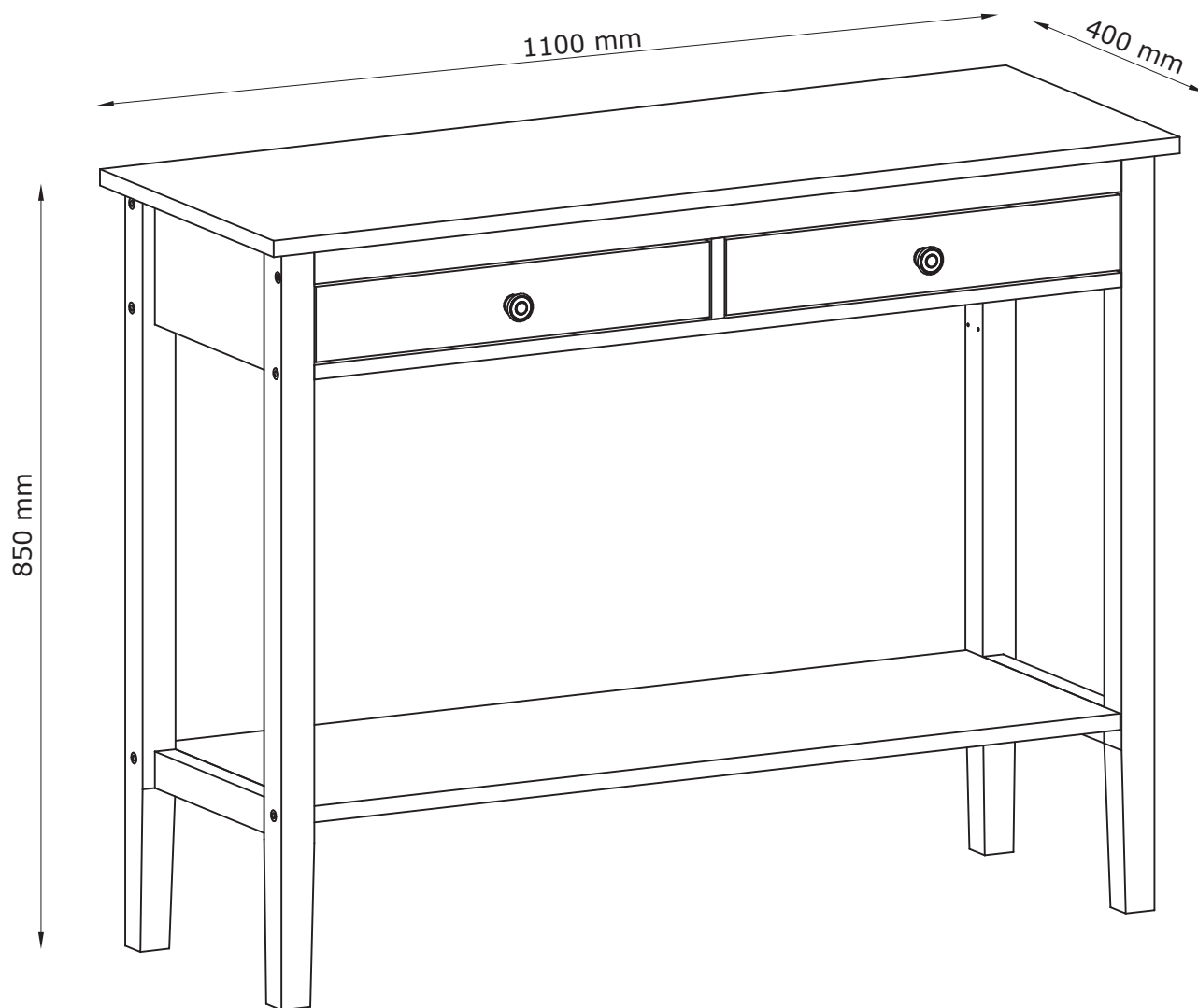

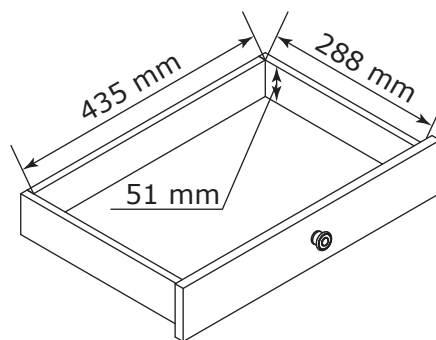
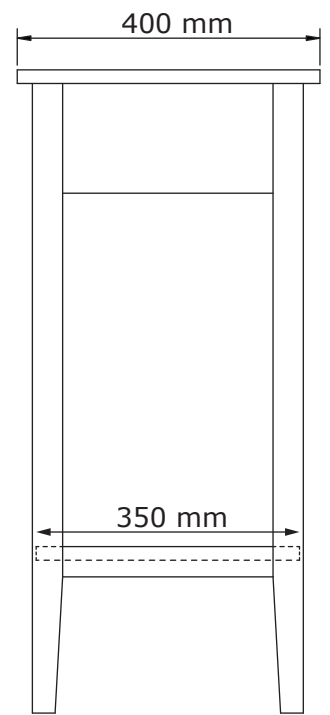
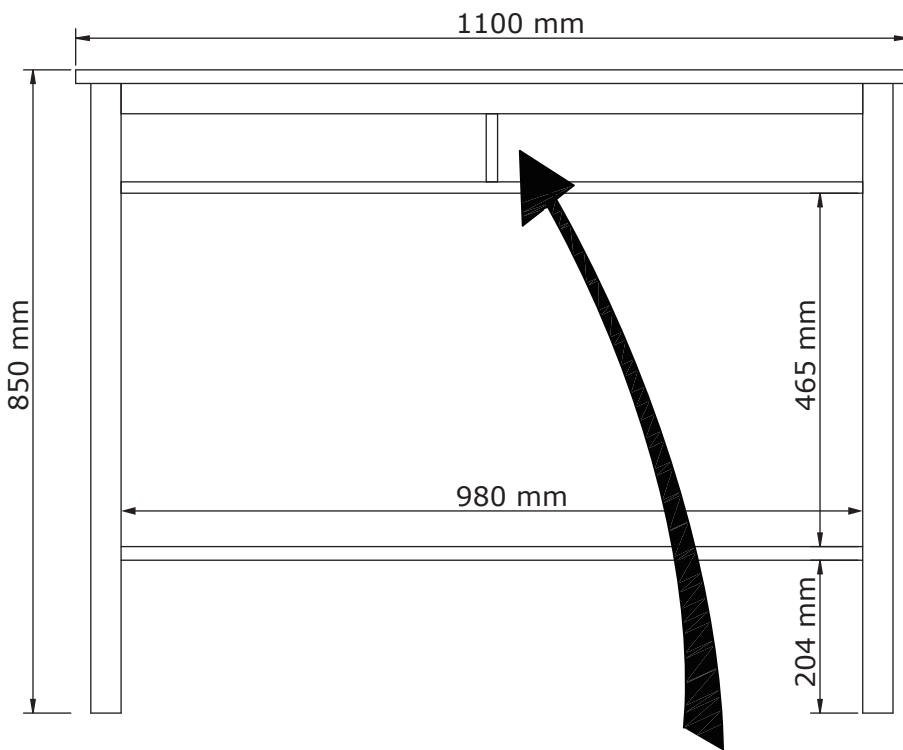
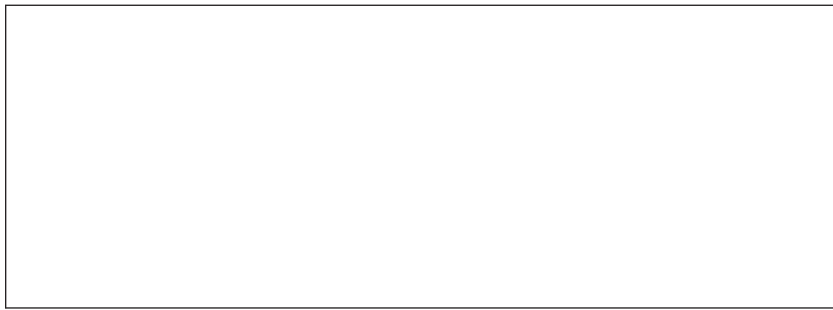
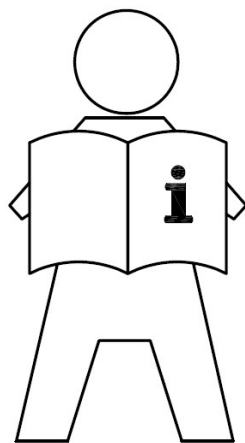

EN: IMPORTANT INFORMATION!

Please read the entire manual carefully before starting to assemble and/or using this product. Follow the manual thoroughly and keep it for further reference.

FR: INFORMATIONS IMPORTANTES

Veillez lire attentivement l'ensemble du manuel avant de commencer à monter et/ou utiliser ce produit. Suivez rigoureusement le manuel et conservez-le pour toute consultation ultérieure.

LV: SVARĪGA INFORMĀCIJA!

Pirms šī izstrādājuma montāžas un/vai lietošanas uzsākšanas pilnībā izlasiet lietošanas pamācību. Stingri ievērojiet pamācības norādījumus un saglabājiet to turpmākai lietošanai.

LT: SVARBI INFORMACIJA!

Prieš pradėdami montuoti gaminį ir (arba) juo naudotis, prašome atidžiai perskaityti visą vadovą. Atidžiai skaitykite vadovą ir turėkite jį su savimi, kad galėtumėte toliau vadovautis jo nuorodomis.

EE: OLULINE TEAVE!

Enne kui alustate toote kokku panemist ja/või kasutamist, lugege see kasutusjuhend hoolikalt läbi. Järgige täpselt juhendis toodud juhiseid ja hoidke juhend alles.

RU: ВАЖНАЯ ИНФОРМАЦИЯ!

Внимательно и полностью прочитайте это руководство, прежде чем приступать к сборке или использованию этого изделия. Следуйте всем инструкциям этого руководства и сохраните его на будущее для справки.

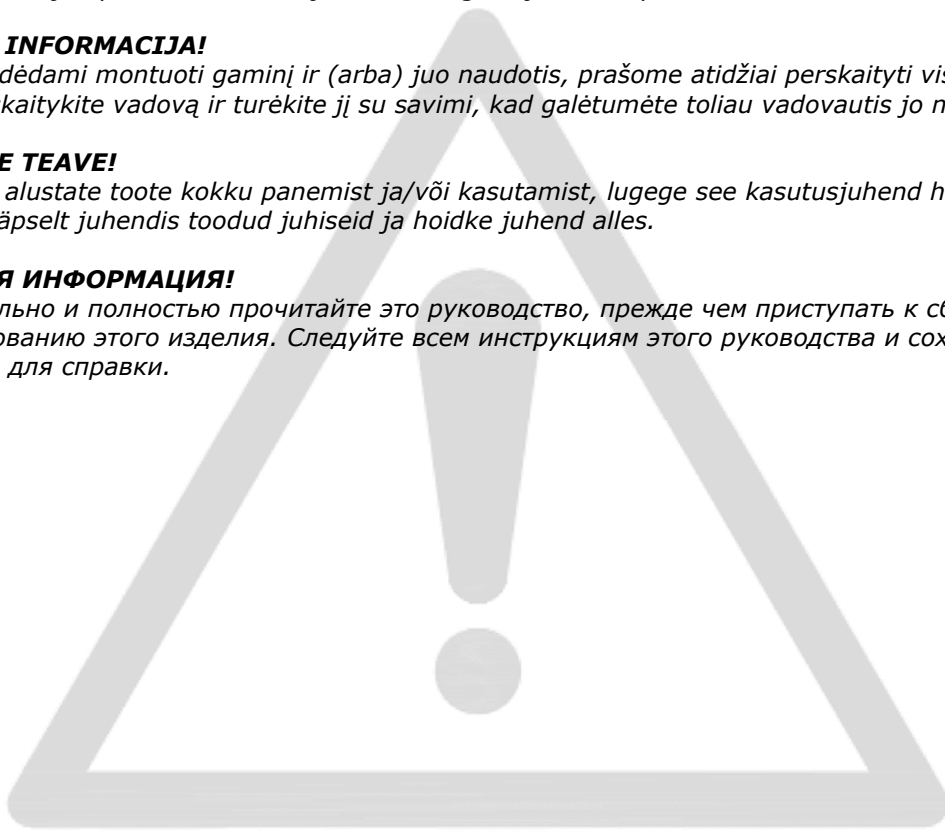

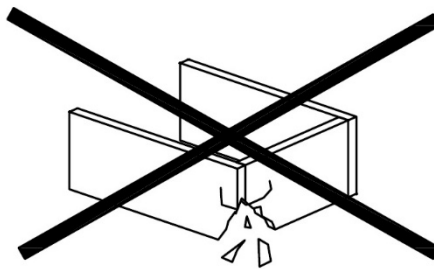
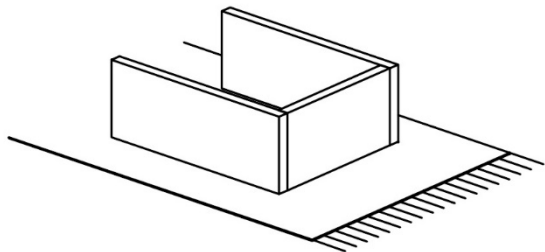

EN: WARNING TO AVOID SCRATCHES!

In order to avoid scratching this furniture should be assembled on a soft layer - could be a rug.

FR: AVERTISSEMENT POUR ÉVITER LES RAYURES

Afin d'éviter les rayures, ce meuble doit être monté sur une surface souple (un tapis, par exemple).

LV: BRĪDINĀJUMS PAR SKRĀPĒJUMIEM!

Lai nesaskrāpētu šo izstrādājumu, veiciet montāžu uz mīkstas pamatnes, piemēram, paklāja.

LT: ĮSPĖJIMAS, KAD IŠVENGTUMĖTE ĮBRĖŽIMŲ!

Šio baldo nesubraižysite, jei jį surinksite ant švelnaus paviršiaus, pavyzdžiui, kilimo.

EE: HOIATUS KRIIMUSTUSTE VÄLTIMISEKS!

Kriimustuste tekkimise vältimiseks mööblile tuleb see kokku panna pehmel pinnal, nt kaltsuvaibal.

RU: ПРЕДУПРЕЖДЕНИЕ ОТНОСИТЕЛЬНО ЦАРАПИН!

Во избежание нанесения царапин, сборку этой мебели необходимо выполнять на мягкой поверхности, например на ковре.

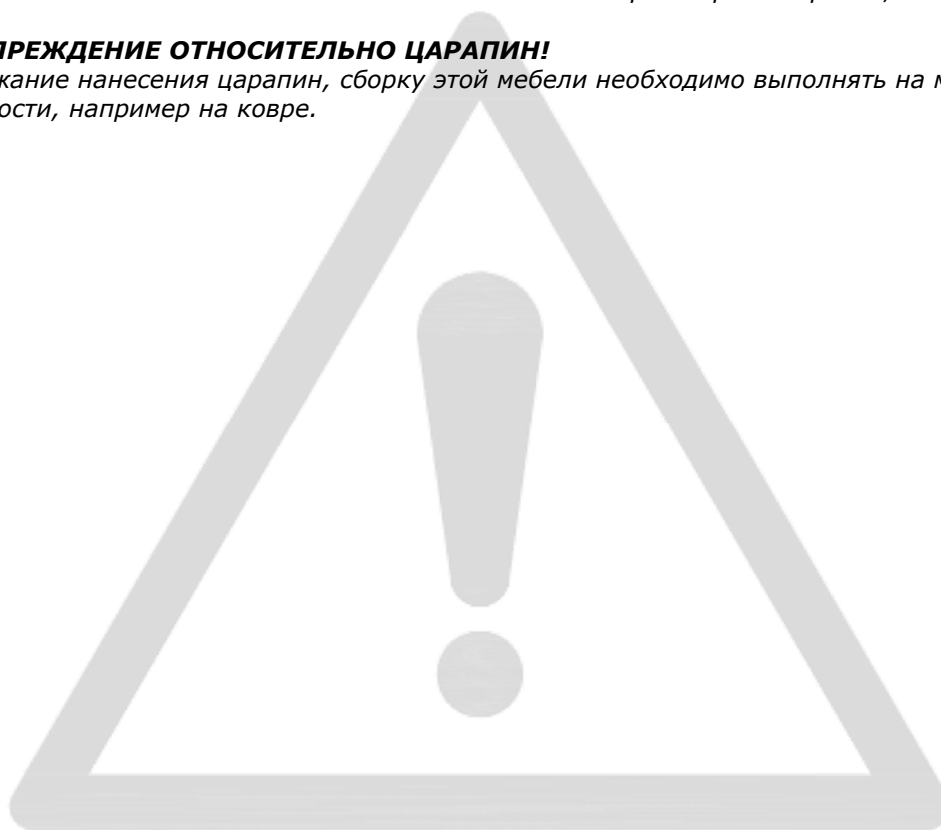

EN: IMPORTANT!

It is important that any product which is assembled using any kind of screw is re-tightened 2 weeks after assembly, and once every 3 months - in order to assure stability through-out the lifespan of the product.

FR: IMPORTANT

Il est important que tout produit monté à l'aide de vis soit resserré 2 semaines après son montage, puis tous les 3 mois, afin de garantir sa stabilité durant tout son cycle de vie.

LV: SVARĪGI!

Ir svarīgi, lai jebkuram produktam, kas tiek uzstādīts ar jebkādu skrūvju palīdzību, skrūves tiktu atkārtoti pievilktas 2 nedēļas pēc montāžas, pēc tam – reizi 3 mēnešos, tā nodrošinot stabilitāti visā izstrādājuma kalpošanas laikā.

LT: SVARBU!

Bet kokį varžtais tvirtinamą gaminį 2 savaites po surinkimo bei kas 3 mėnesius reikia papildomai suveržti – taip užtikrinamas naudojamo gaminio stabilumas.

EE: TÄHTIS!

Oluline on, et toote kruvisid pingutataks 2 nädalat pärast kokkupanekut ja seejärel iga 3 kuu järel, et tagada stabiilsus kogu toote eluea jooksul.

RU: ВАЖНО!

В любом изделии, собранном с использованием винтов любого типа, необходимо через 2 недели после сборки и в дальнейшем каждые 3 месяца подтягивать винты, чтобы обеспечить прочность изделия в течение срока эксплуатации.





EN: GENERAL INSTRUCTION FOR FURNITURE MADE OF WOOD OR WOOD COMPOSITES SUCH AS MELAMINE, LAMINATE OR VENEER SURFACES!

Wipe clean with a damp cloth. Use only water or a gentle detergent.
Wipe dry with a clean cloth.

FR: INSTRUCTIONS GÉNÉRALES POUR LE MOBILIER CONSTITUÉ DE BOIS OU DE COMPOSITES DE BOIS (COMME LES SURFACES EN MELAMINÉ, STRATIFIÉ OU PLACAGE)

Nettoyer à l'aide d'un chiffon humide. Utiliser uniquement de l'eau ou un détergent doux.
Essuyer à l'aide d'un chiffon propre.

LV: VISPĀRĒJI NORĀDĪJUMI MĒBELĒM NO KOKA VAI KOKSNES KOMPOZĪTIEM, PIEMĒRAM, MELAMĪNA, LAMINĀTA VAI FINIERA VIRSMĀM!

Noslaukiet ar mitru drānu. Lietojiet tikai ūdeni vai maigu mazgāšanas līdzekli.
Nosusiniet ar tīru drānu.

LT: BALDŲ IŠ MEDIENOS AR MEDIENOS KOMPOZITO, DENGTO MELAMINU, LAMINATU AR PLONU FANEROS SLUOKSNIU, BENDRIEJI VALYMO NURODYMAI!

Valykite drėgnu skudurėliu. Naudokite tik vandenį arba švelnų valiklį.
Nusausinkite švari skudurėliu.

EE: PUIDUST VÕI MITMEKIHILISEST PUIDUST, NAGU MELAMIINIST, LAMINAADIST VÕI VINEERIST MÖÖBLI ÜLDJUHISED!

Kasutage puhastamiseks niisket lappi. Kasutage ainult vett või õrnatoimelist puhastusvahendit.
Pühkige puhta lapiga kuivaks.

RU: ОБЩИЕ УКАЗАНИЯ ОТНОСИТЕЛЬНО МЕБЕЛИ, ИЗГОТОВЛЕННОЙ ИЗ ДЕРЕВА ИЛИ ДРЕВЕСНЫХ КОМПОЗИЦИОННЫХ МАТЕРИАЛОВ, ТАКИХ КАК МЕЛАМИН, ЛАМИНАТ ИЛИ ШПОН!

Очистите изделие чистой влажной тканью. Используйте мягкодействующее моющее средство.
Вытрите досуха чистой тряпкой.

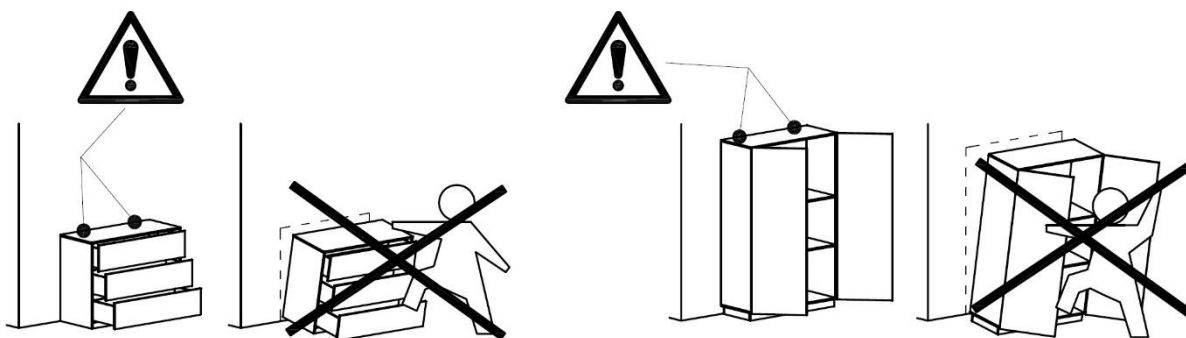

EN: ANTI-TOPPLE WARNING!

This product has to be permanently fixed to the wall with the bracket(s) included, to avoid fatal injury in case it topples over. The pack only contains screws for fastening the anti-topple bracket(s) itself to the product. Please contact your DIY or hardware store for advice on the correct type of screws/raw plugs for your type of wall.

FR: AVERTISSEMENT ANTIBASCULEMENT

Ce produit doit être fixé de manière permanente au mur à l'aide du/des support(s) inclus afin d'éviter des blessures mortelles en cas de basculement. L'emballage contient des vis pour attacher le(s) support(s) antibasculement au produit. Veuillez contacter votre magasin de bricolage ou votre quincaillerie pour obtenir des conseils sur le type de vis/chevilles adapté à votre mur.

LV: BRĪDINĀJUMS PAR APGĀŠANOS!

Šis produkts ir jāpiestiprina pie sienas ar komplektā iekļauto(-ajiem) kronšteinu(-iem), lai novērstu nāvējošu savainojumu risku, tam apgāžoties. Iepakojumā ir skrūves tikai pretapgāšanās kronšteina(-u) piestiprināšanai pie produkta. Informāciju par to, kādas skrūves piemērotas Jūsu sienai, jautājiet saimniecības preču vai būvizstrādājumu veikalā.

LT: ĮSPĖJIMAS DĖL NUVERTIMO!

Šį gaminį būtina tinkamai pritvirtinti prie sienos naudojant pridėtas gembes, kad išvengtumėte mirtino sužalojimo jam nuvirtus. Pakuotėje yra tik varžtai gembėms prie gaminio pritvirtinti. Užeikite į artimiausią statybinių prekių parduotuvę ir paprašykite savo sienai tinkamiausių varžtų (kaiščių).

EE: ÜMBERKUKKUMISOHT!

Toote ümberkukkumisest tuleneda võiva eluohtliku õnnetuse vältimiseks tuleb see kinnitada komplekti kuuluva(te) kronsteini(de) abil püsivalt seina külge. Komplekti kuuluvad ainult kruvid, mis on mõeldud ümberkukkumist takistava(te) kronsteini(de) kinnitamiseks toote külge. Soovituste saamiseks sobivate kruvide/tüüblite leidmiseks oma seina jaoks, konsulteeriage DIY esindaja või rauakaupade kaupluse müüjaga.

RU: ПРЕДУПРЕЖДЕНИЕ ОБ ОПРОКИДЫВАНИИ!

Во избежание опрокидывания это изделие должно быть надежно прикреплено к стене с помощью прилагаемых кронштейнов. В комплект входят винты только для прикрепления кронштейнов к самому изделию. Шурупы и дюбели для крепления к стене конкретного типа можно найти в строительном или хозяйственном магазине.

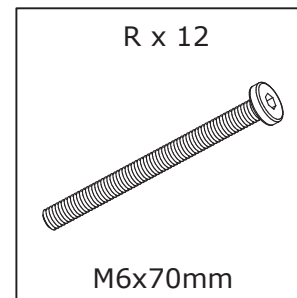
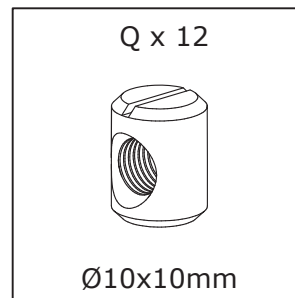
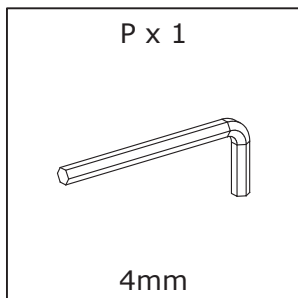
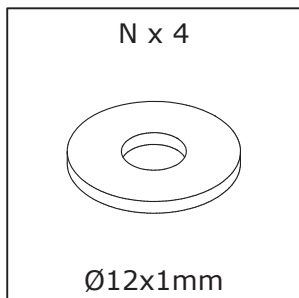
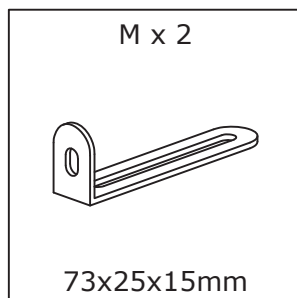
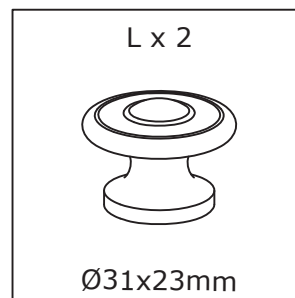
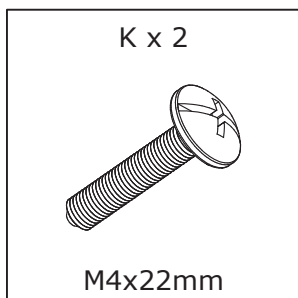
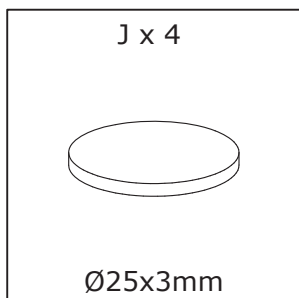
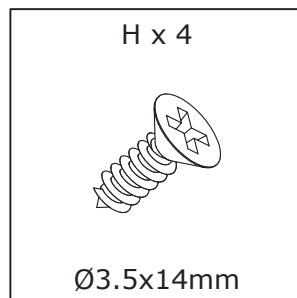
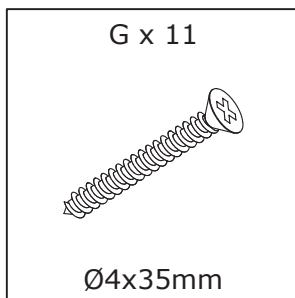
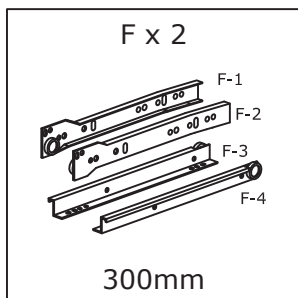
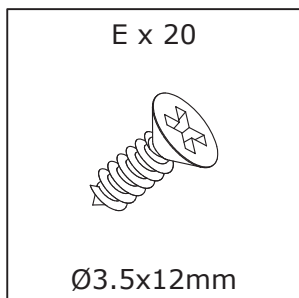
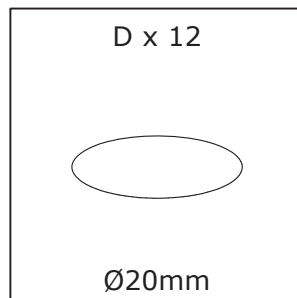
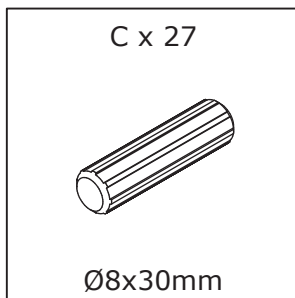
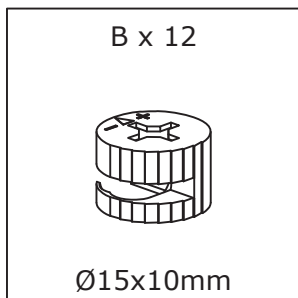
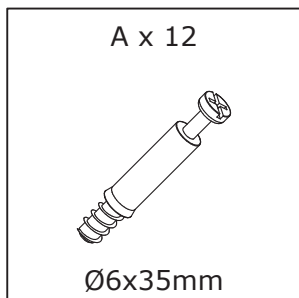
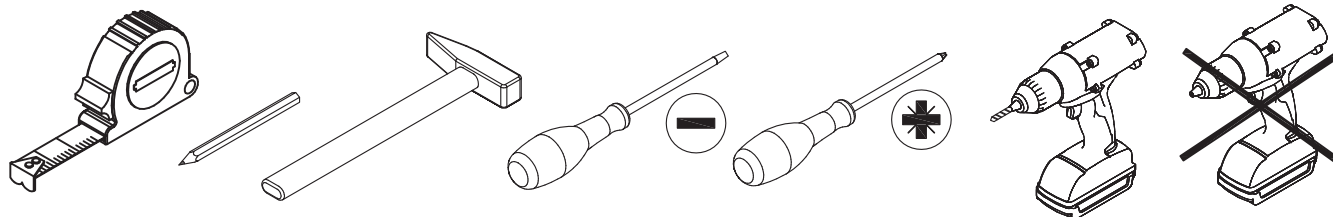

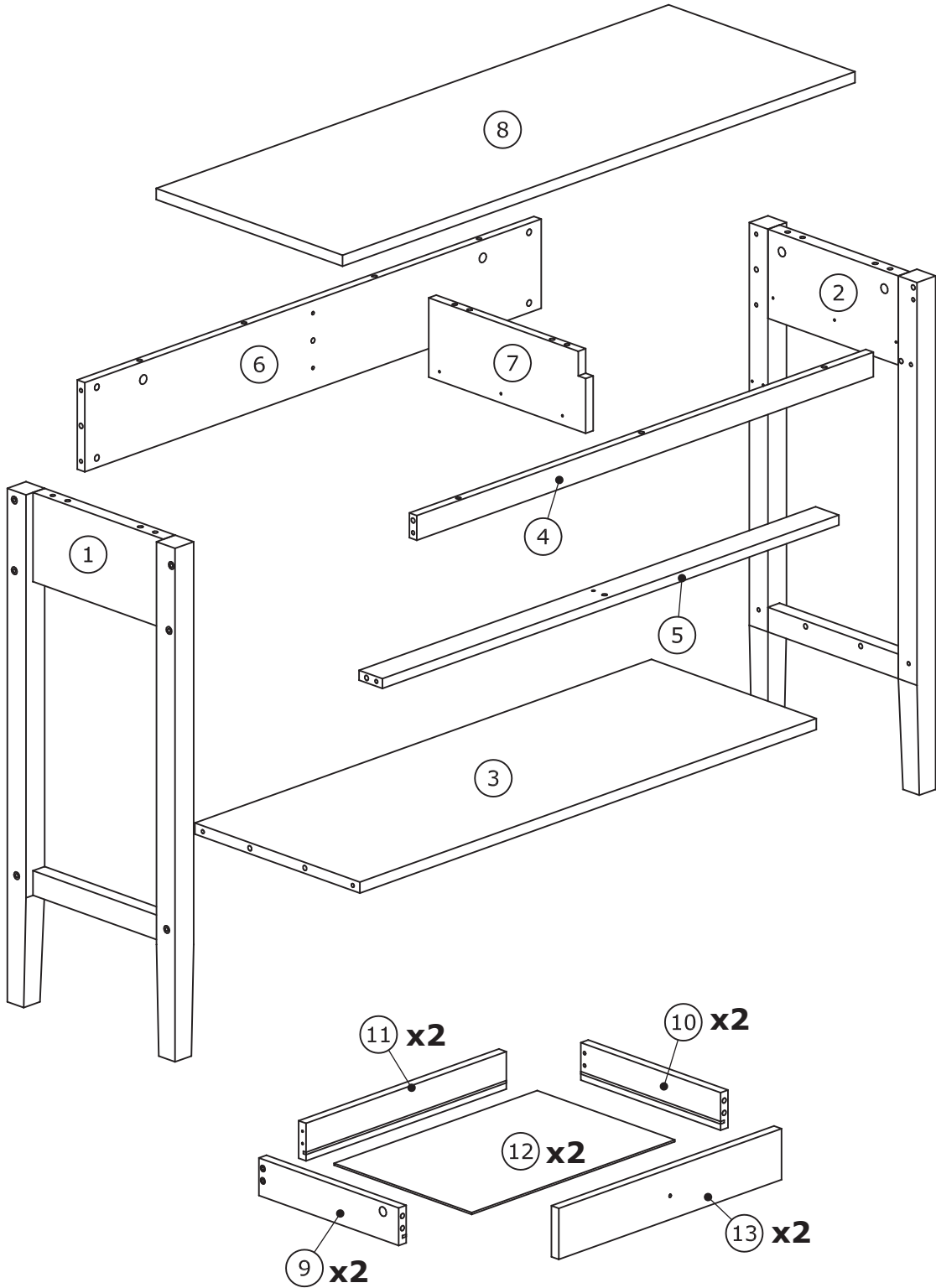

Box 1/1:

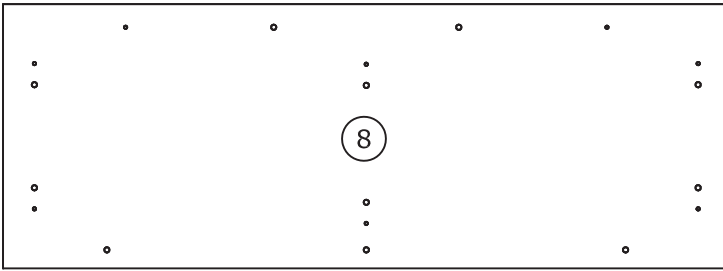

1100 x 400 x 18 mm

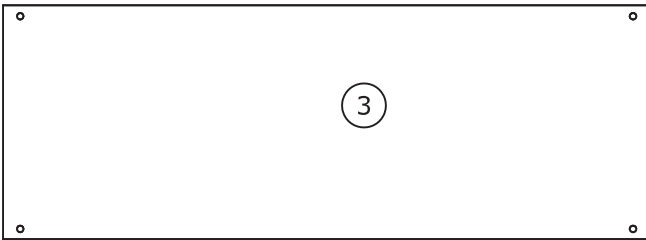

983 x 350 x 18 mm

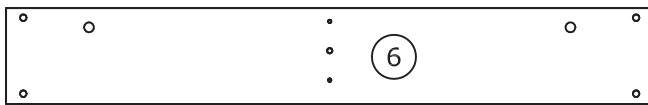

983 x 145 x 15 mm

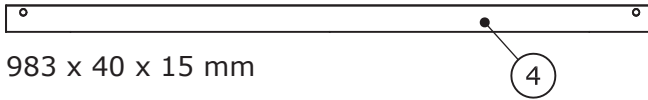

983 x 40 x 15 mm

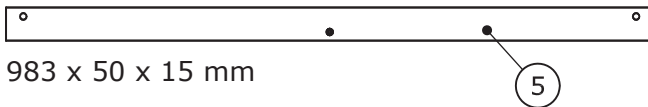

983 x 50 x 15 mm



444 x 296 x 3 mm

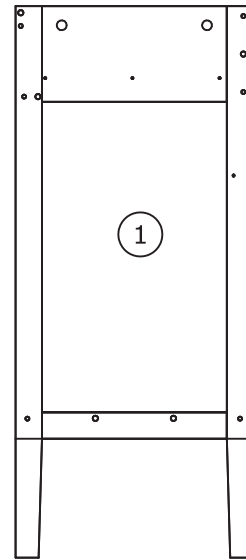

832 x 360 x 40 mm

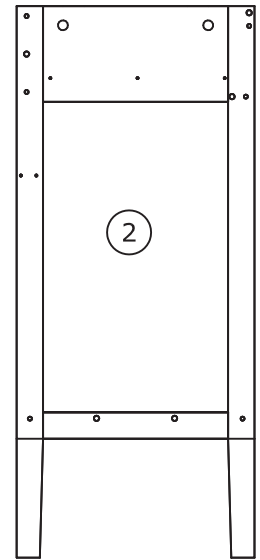

832 x 360 x 40 mm



333 x 133 x 15 mm

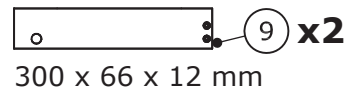

300 x 66 x 12 mm

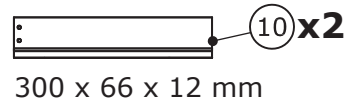

300 x 66 x 12 mm

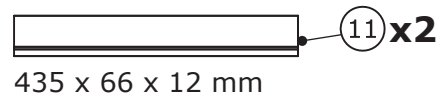

435 x 66 x 12 mm

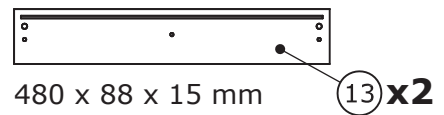

480 x 88 x 15 mm

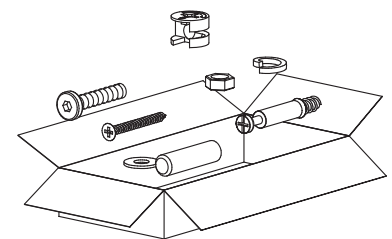

1



$$F = (F-1) + (F-2) + (F-3) + (F-4)$$

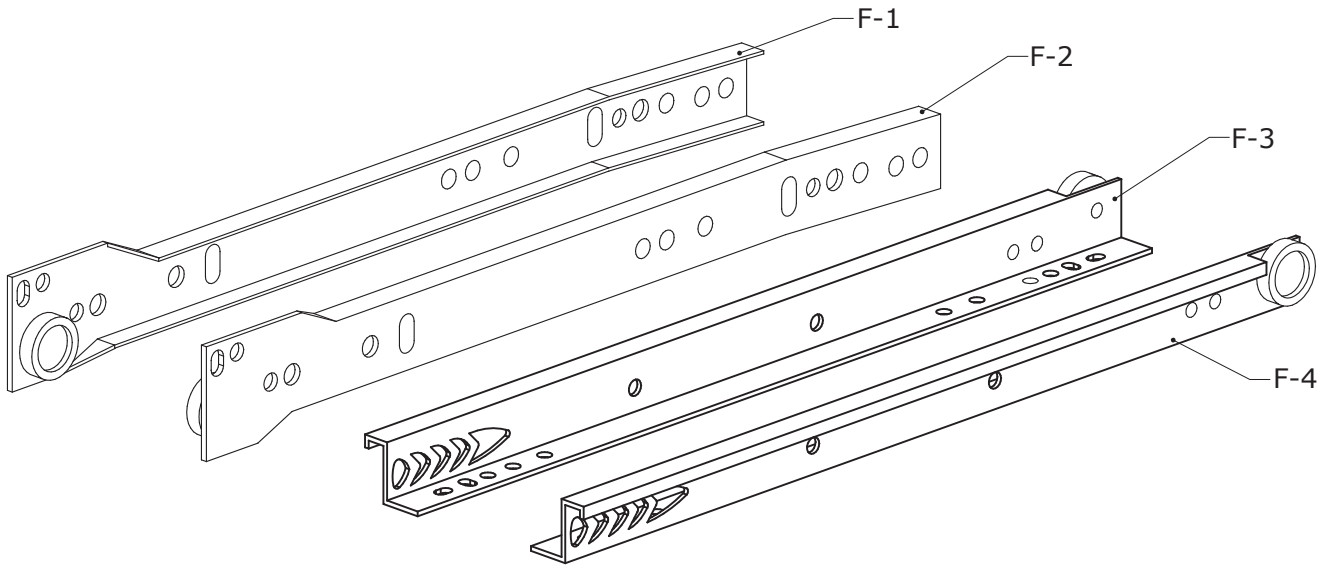

2

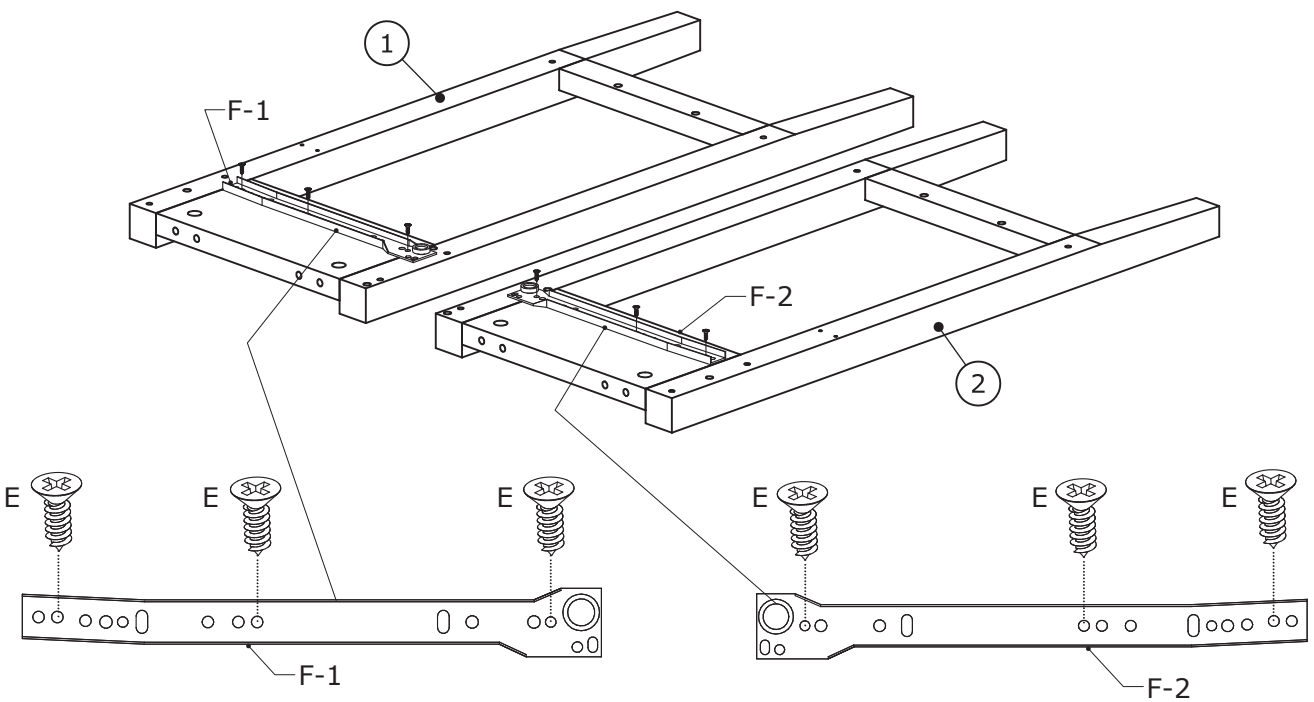
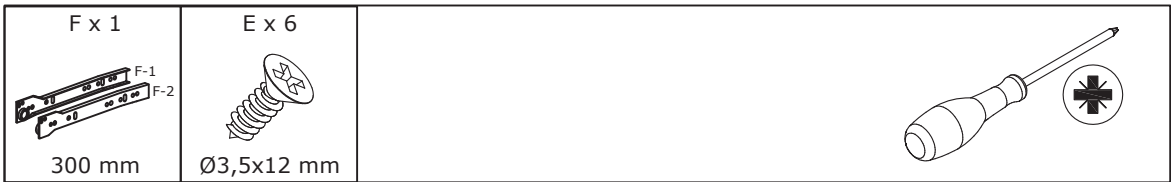

3

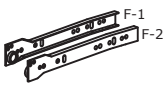
<p>F x 1</p>  <p>300 mm</p>	<p>E x 6</p>  <p>Ø3,5x12 mm</p>	
--	--	---

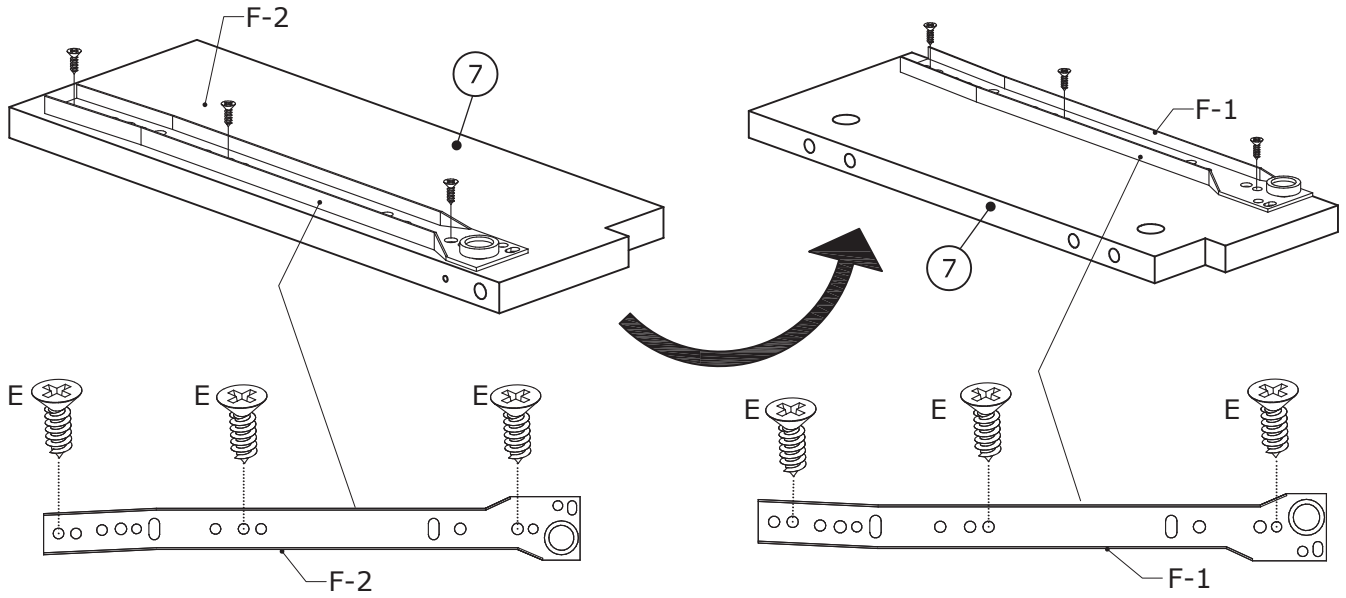

4

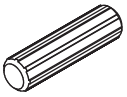
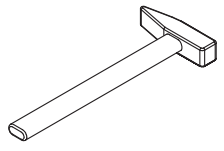
<p>C x 12</p>  <p>Ø8x30 mm</p>	
---	---

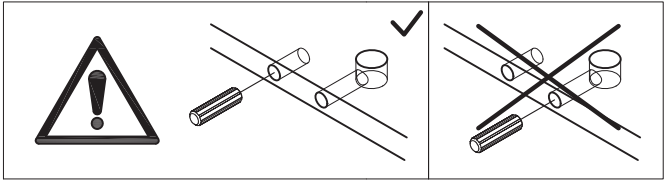
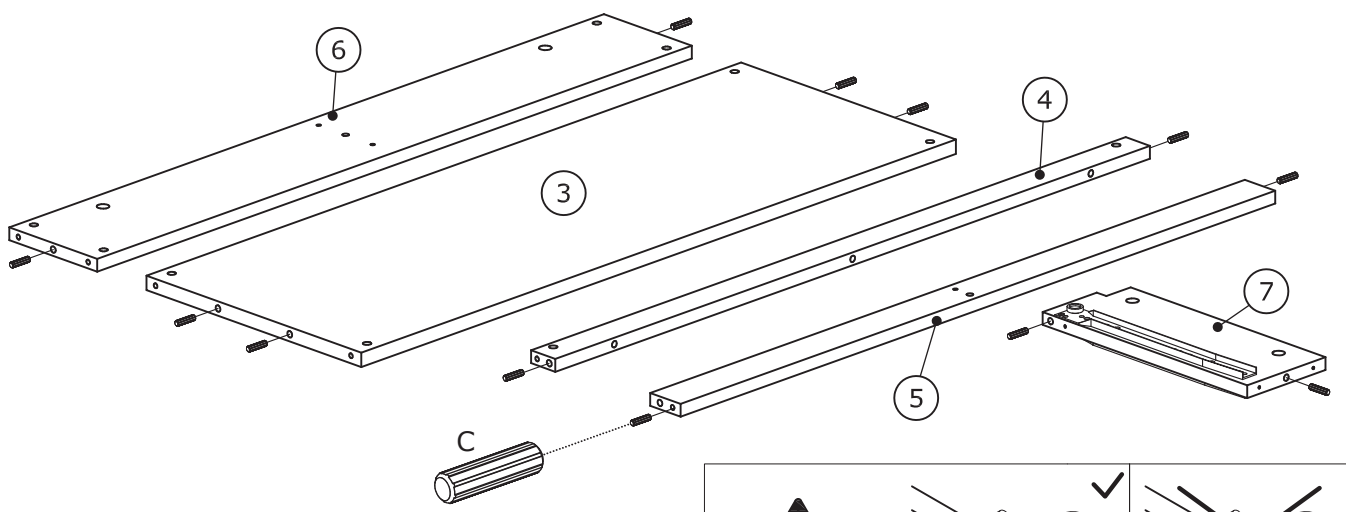

5

G x 2
Ø4x35 mm



A technical illustration of a screw with a cross-shaped head and a corresponding screwdriver icon.

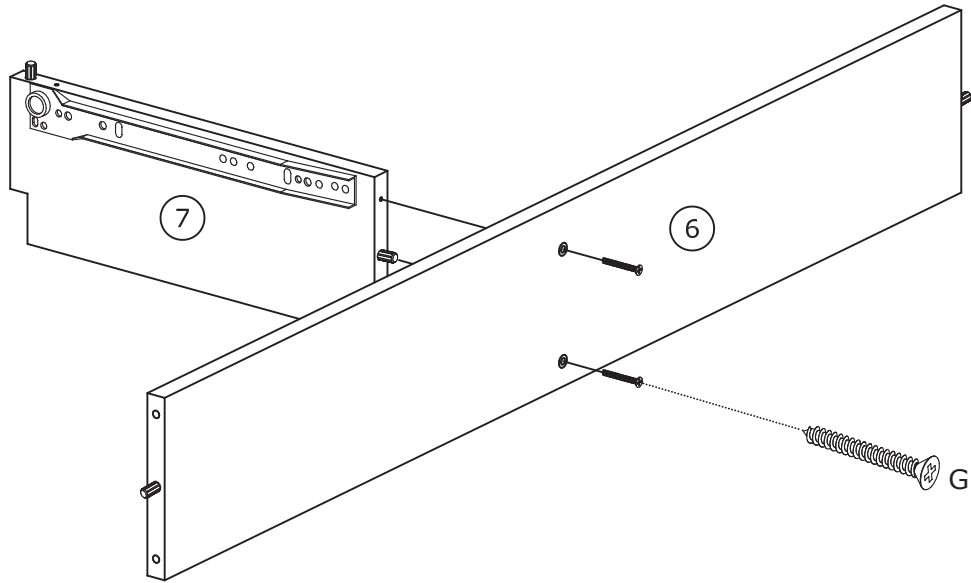

6

G x 1
Ø4x35 mm



A technical illustration of a screw with a cross-shaped head and a corresponding screwdriver icon.

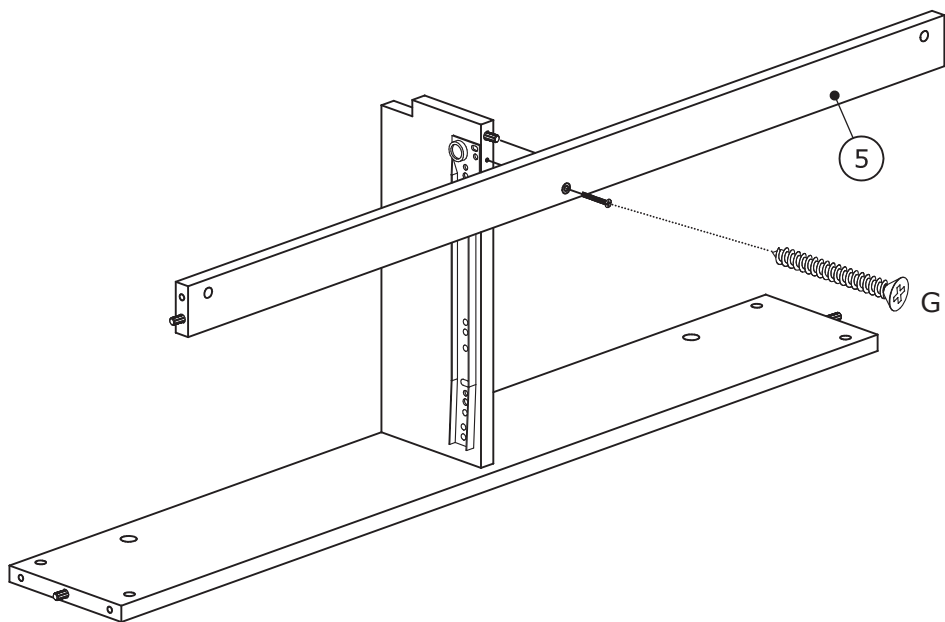

7

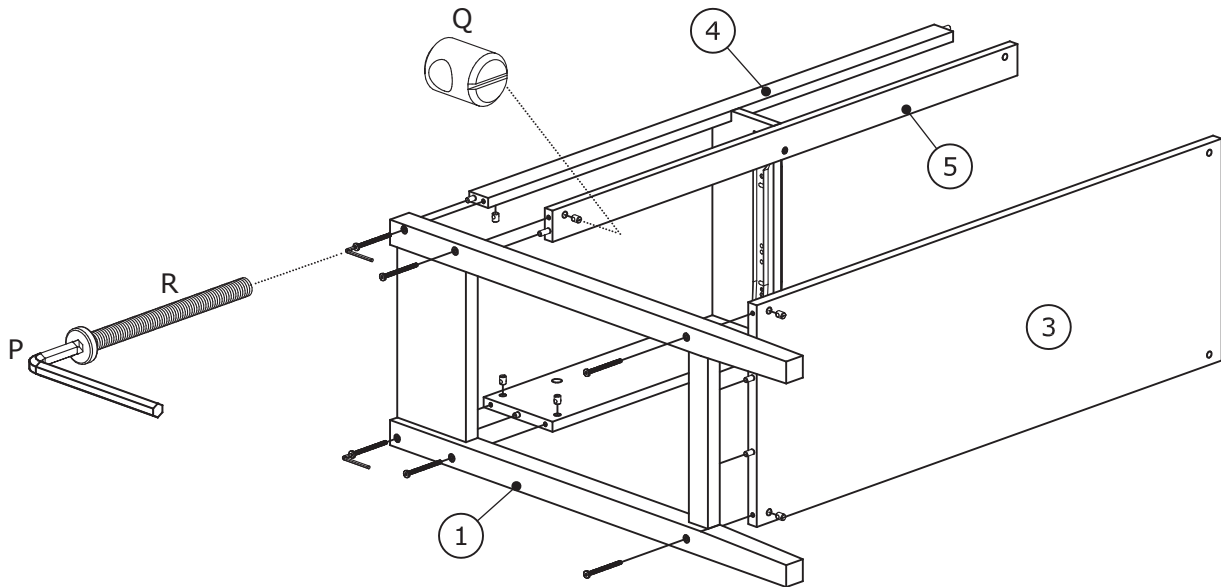
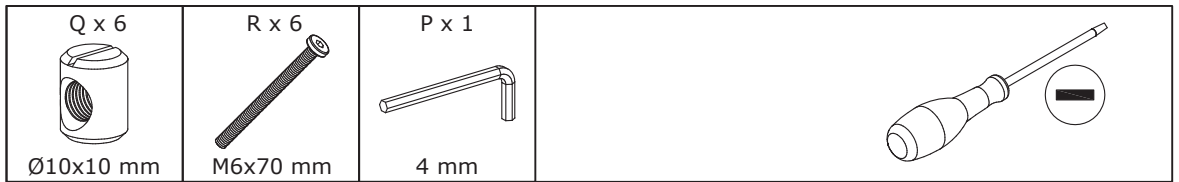

8

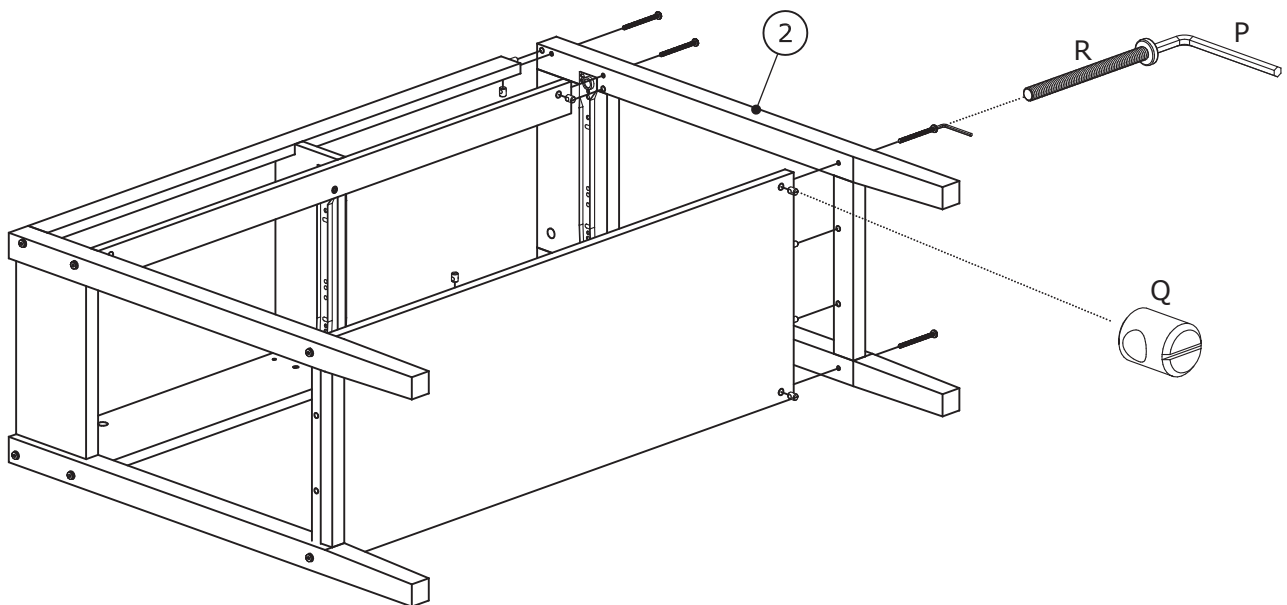
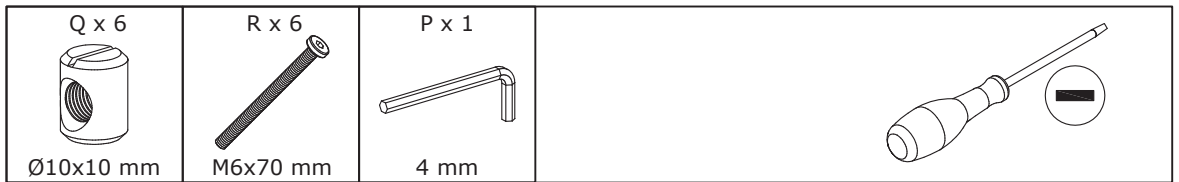

9

J x 4



Ø25x3 mm

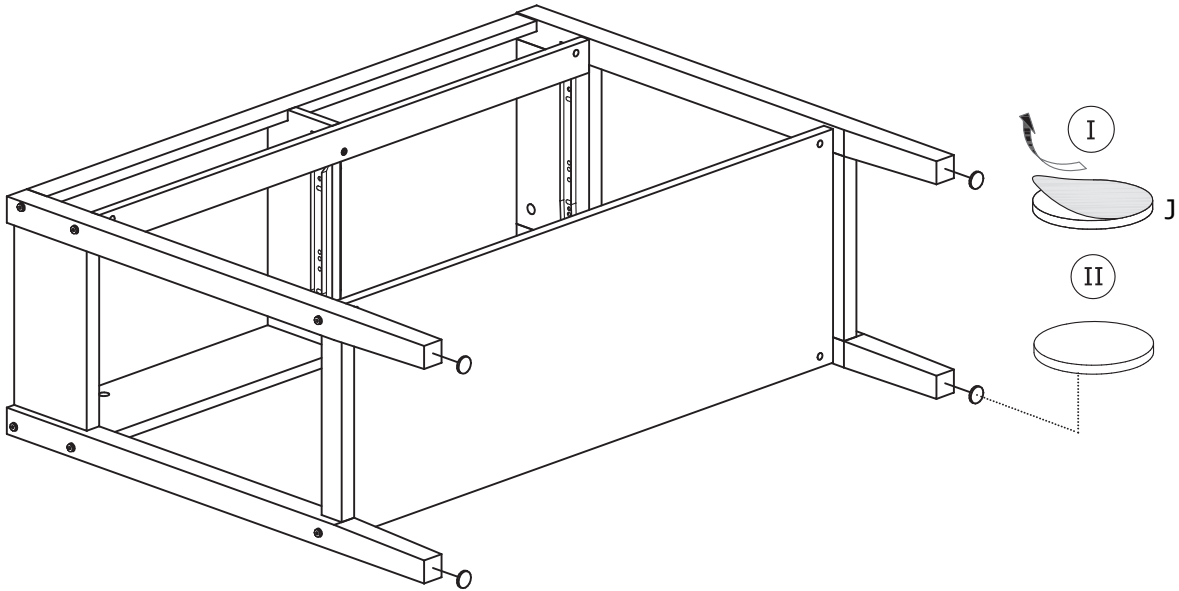

10

A x 8

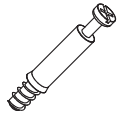

Ø6x35 mm

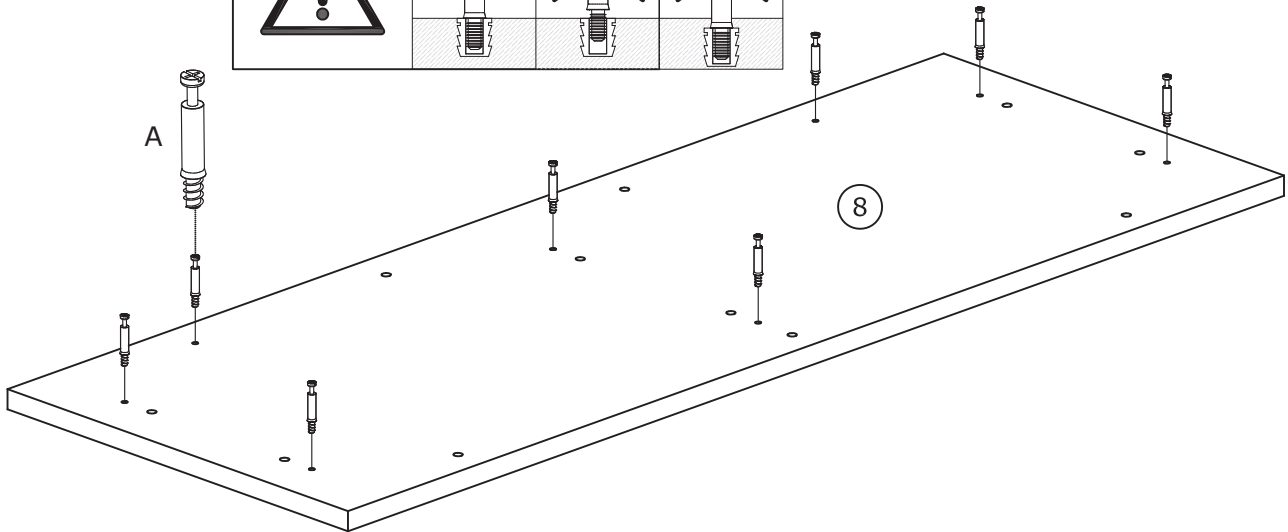
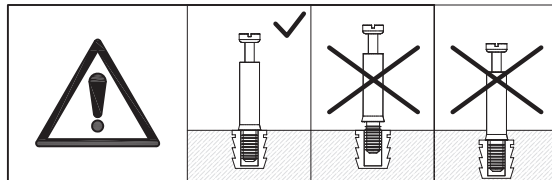
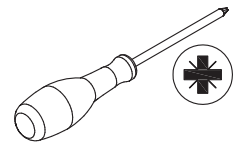

11

C x 11

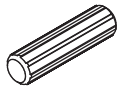

Ø8x30 mm

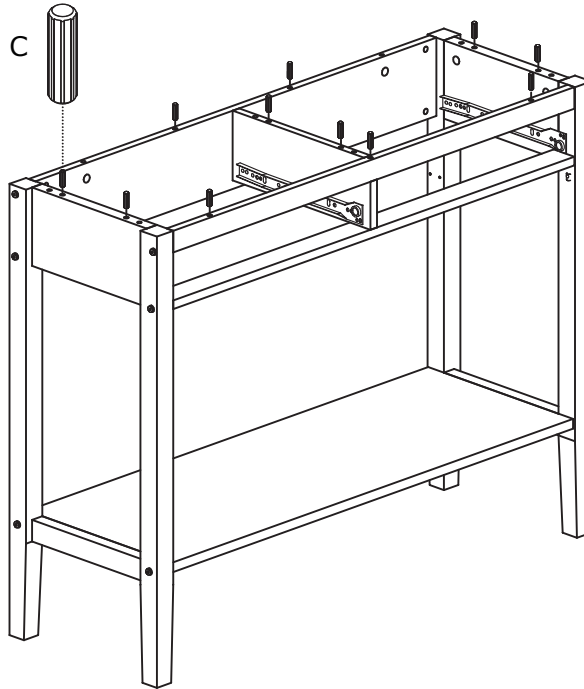
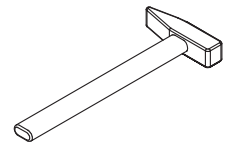

12





B x 8

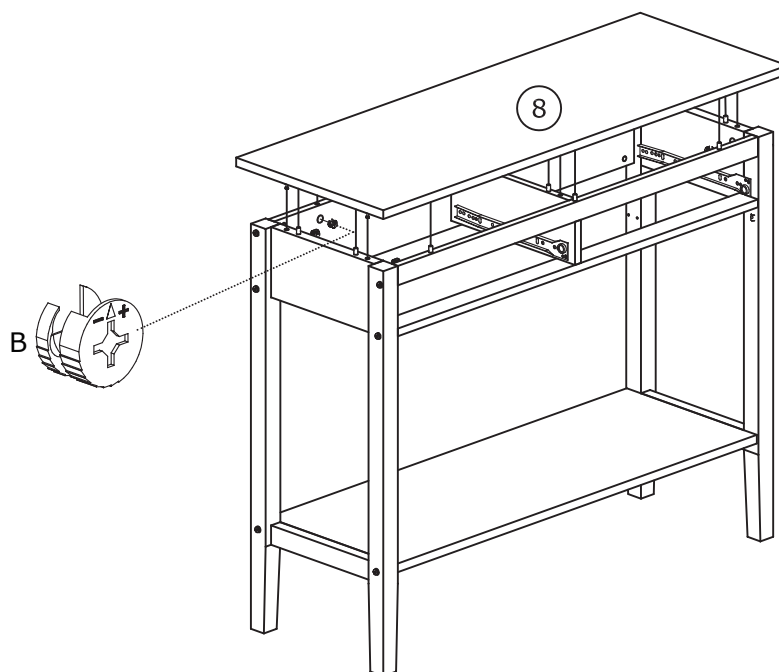
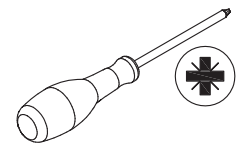

Ø15x10 mm

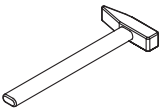
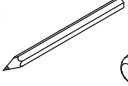
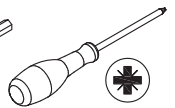

13

H x 4  Ø3,5x14 mm	M x 2  73x25x15 mm	N x 4  Ø12x1 mm	   
--	---	--	---

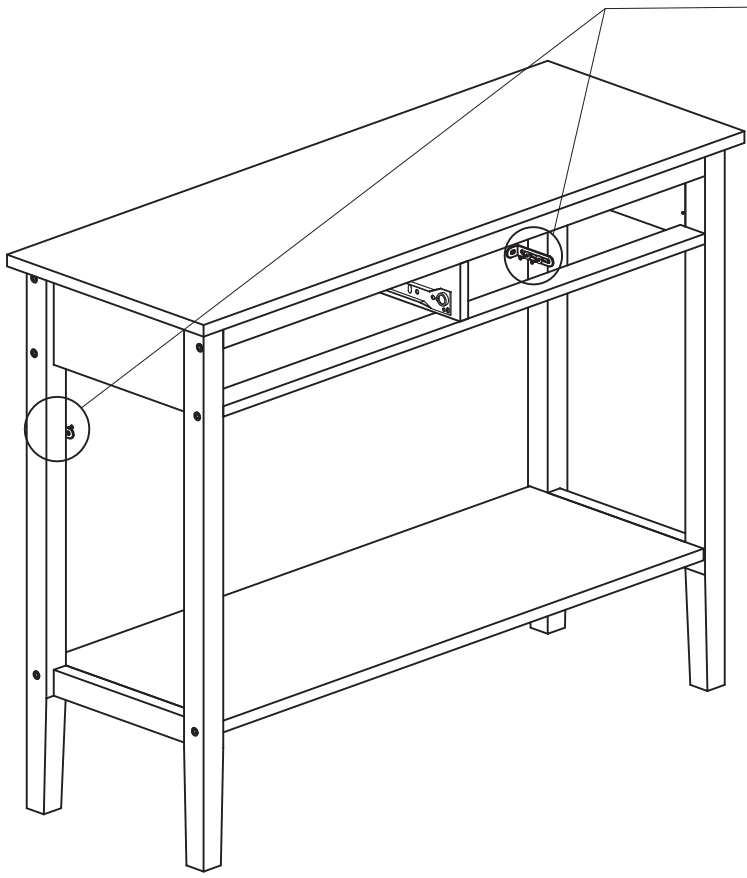
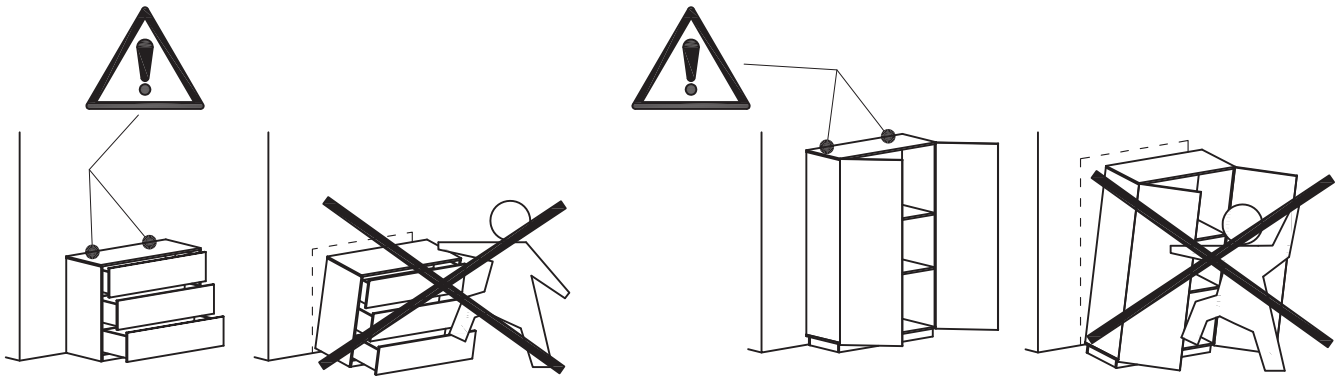

A vertical sequence of six panels (I-VI) showing the assembly of the desk drawer mechanism. Panel I shows the initial assembly with a curved arrow and '80%' indicating progress. Panel II shows a screwdriver being used to adjust a component. Panel III shows a power drill being used. Panel IV shows a bracket being inserted. Panel V shows a screw being inserted. Panel VI shows the final assembly with a curved arrow and '100%' indicating completion.

14

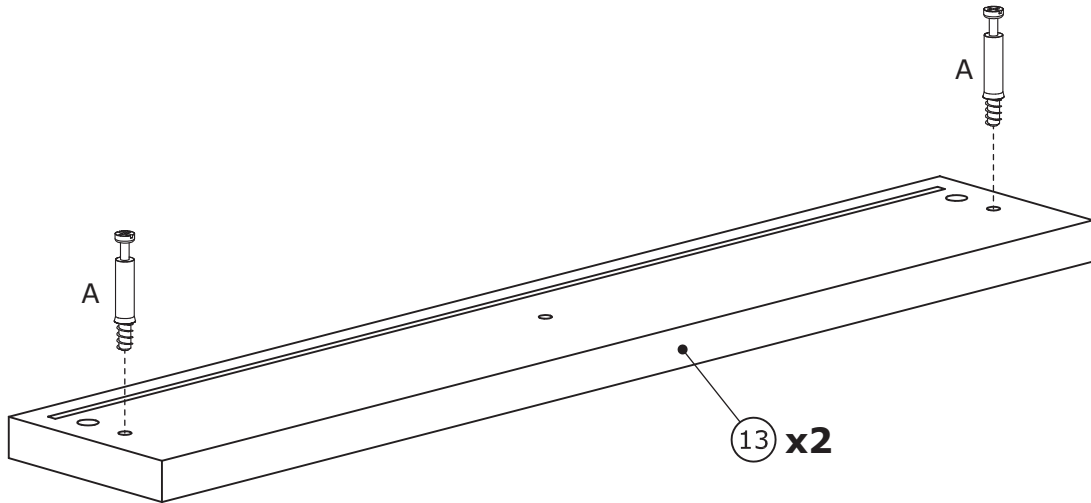

15

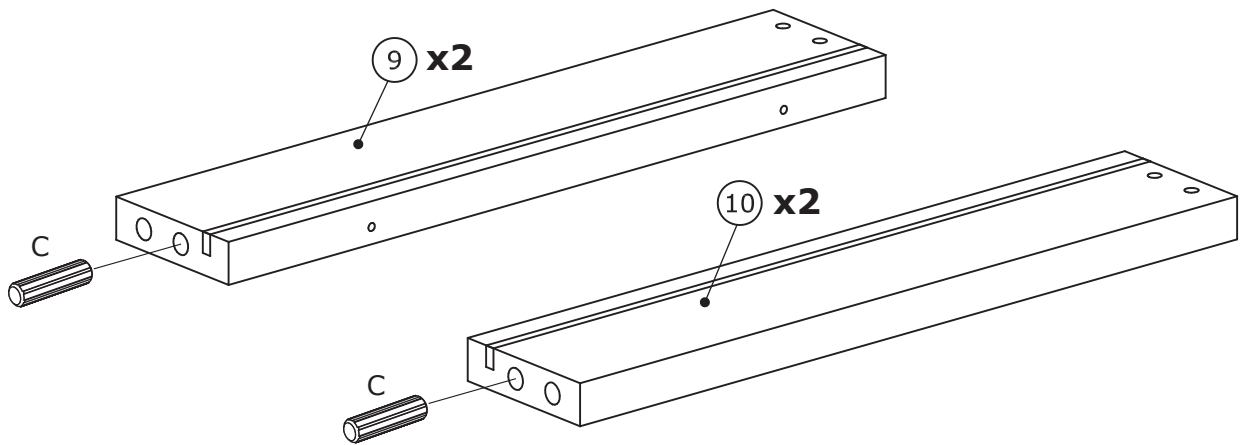

16

B x 4



Ø15x10 mm

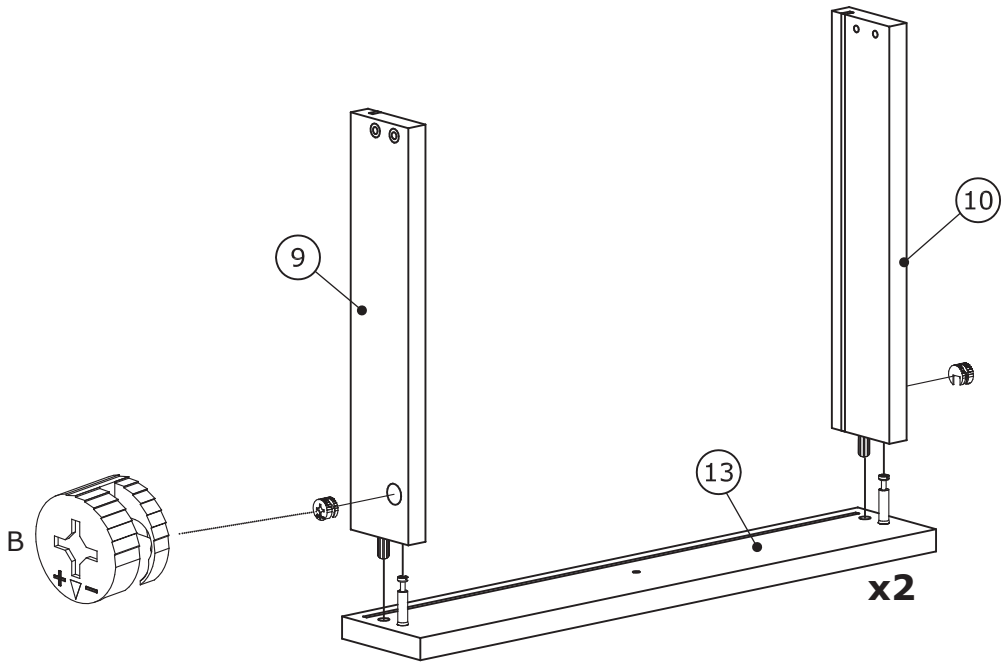

17

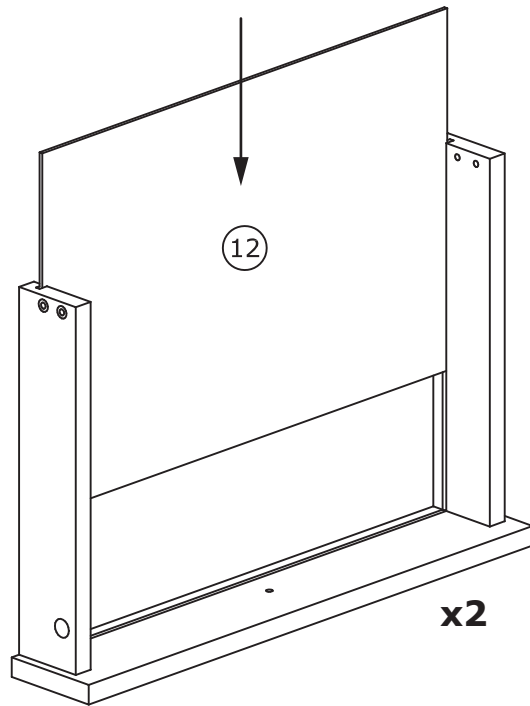

18

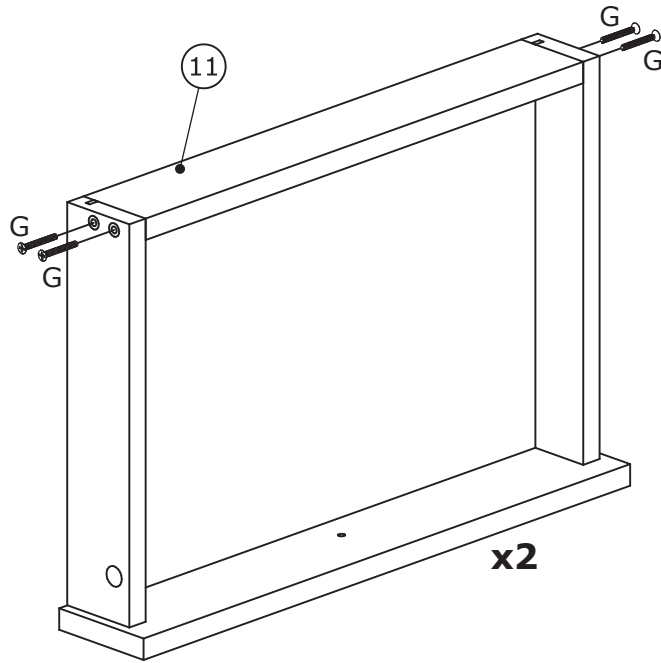

19

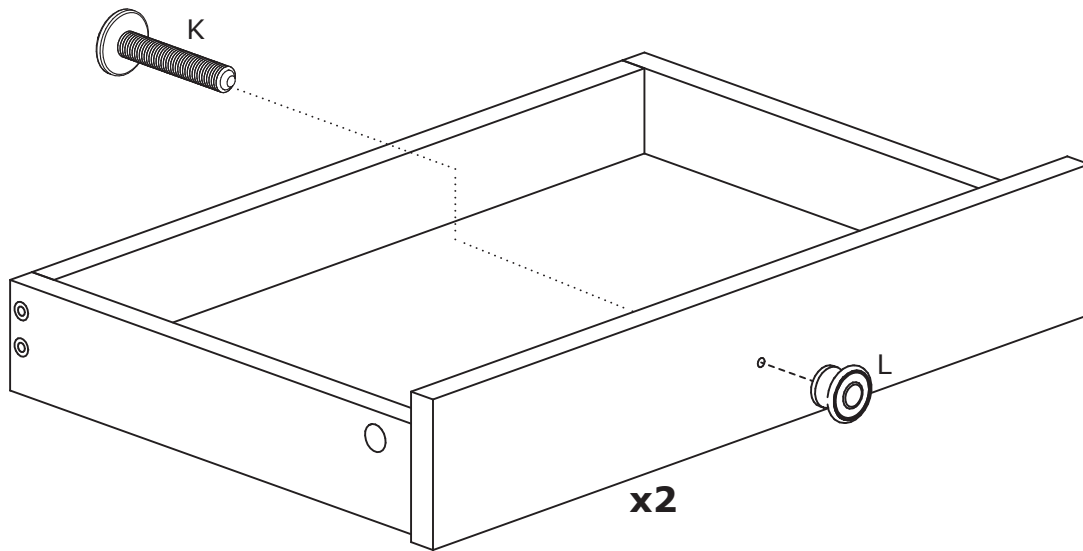
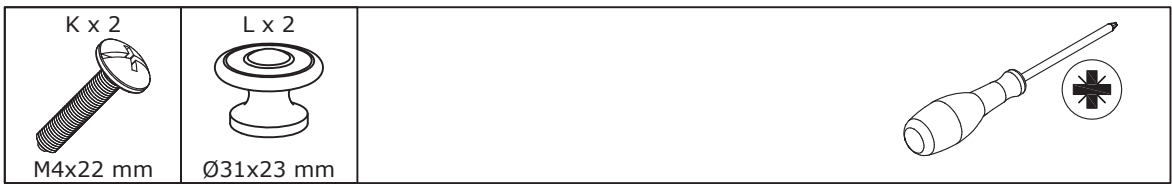

20

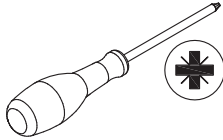
<p>F x 2</p>  <p>300 mm</p>	<p>E x 8</p>  <p>Ø3,5x12 mm</p>	 
--	--	---

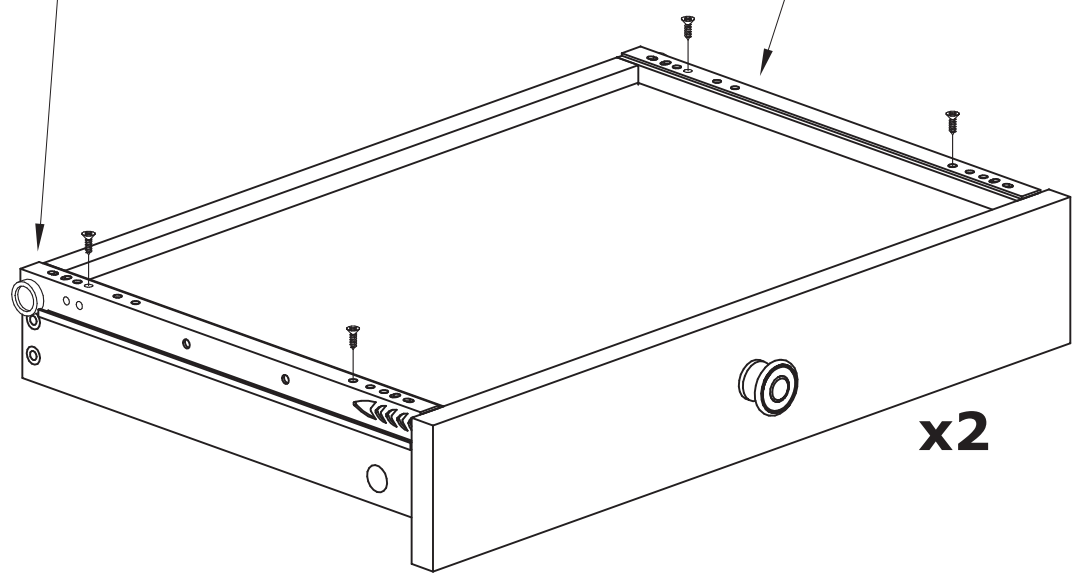
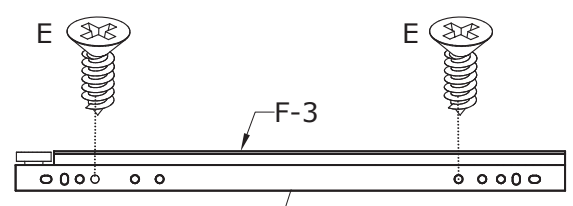
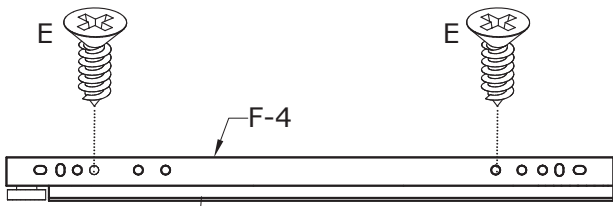

21

D x 12	
	
Ø20 mm	

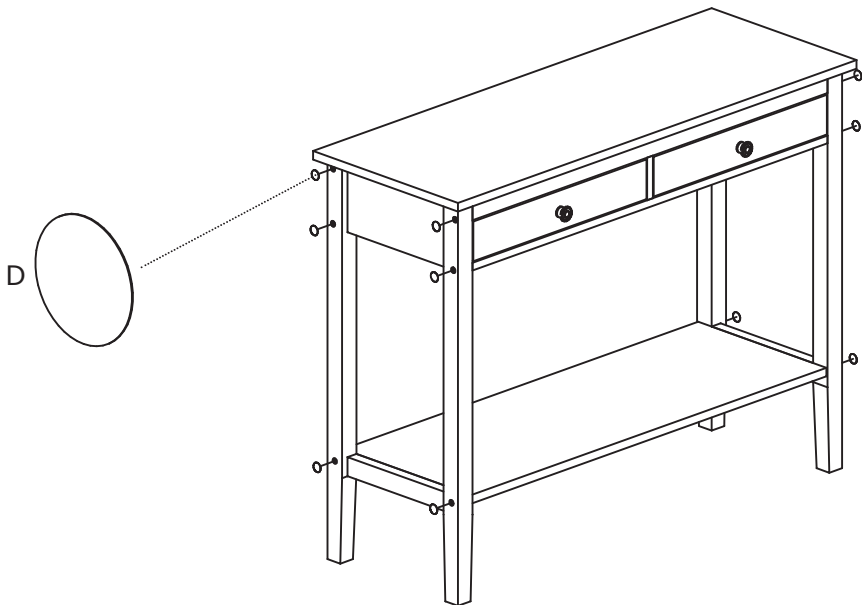

22

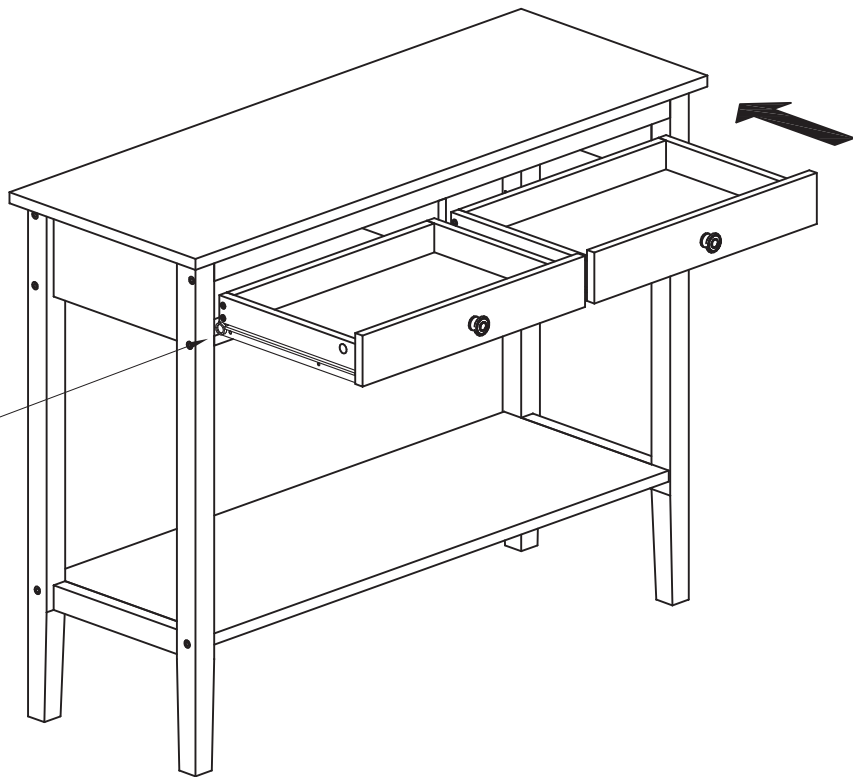
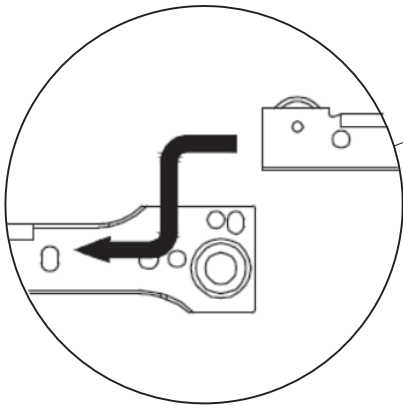

23

